



cima[®]

ATOMIZZATORI-IMPOLVERATORI

New Plus 42-45



**ATOMIZZATORI PNEUMATICI A BASSO VOLUME
PNEUMATIQUES PORTÉS**

Atomizzatori - Pneumatiques



☆ Ampia scelta di testate di distribuzione, tutte dotate del nuovo sistema anti-gocciolamento (brev.N° 1745689) e di dispositivi di diffusione (mani e/o cannoni) di diverse dimensioni, **adattabili in altezza, orientabili ed intercambiabili** per garantire, su tutte le tipologie di colture, un'eccellente copertura e penetrazione nella vegetazione.



☆ Large choix d'équipements de pulvérisation, tous équipés du nouveau système antigoutte (brevet No.1745689) et des dispositifs de diffusion (mains et/ou canons) de dimensions différentes, **adaptables aux hauteurs, orientables et interchangeables**, pour garantir, à chaque type de culture, une meilleure pénétration et une couverture d'excellente qualité de la végétation.

☆ **Regolatori a disco rotante** con 15 fori calibrati (brev.N°23238), sostituiscono il sistema a pastiglie. **Erogazione da 70 a 3400 litri/ora**

☆ **Régulateurs à disques tournants** avec 15 trous calibrés (brevet No.23238) remplacent le système à pastilles. **Débit : de 70 à 3400 lh.**



☆ Serbatoio in polietilene rotazionale, apertura di riempimento di grandi dimensioni (Ø360) con coperchio a cerniera, indicatore di livello.

☆ Serbatoio lavamani integrato l.15.

☆ Serbatoio lavaimpianto integrato nel serbatoio principale (versioni GOLD).

☆ **Idromiscelatore integrato nel filtro a tazza.**

☆ **Doppia agitazione, idraulica e pneumatica.**

☆ **Trasmissione a cinghia poly-V** che assorbe le sollecitazioni. **Funzionamento per oltre 5000 ore.** Il tenditore automatico evita lo slittamento e quindi l'usura. La qualità della polverizzazione resta inalterata nel tempo.

☆ **Ruota libera di sicurezza per arresto improvviso.**

☆ **Transmission à courroie poly-V** qui absorbe toutes tensions. **Plus de 5000 heures de fonctionnement.** Le tendeur automatique évite le glissement et l'usure. La qualité de la pulvérisation reste inalterée longtemps.

☆ **Roue libre de sécurité en cas d'arrêt soudain de la Pdf** (en option).

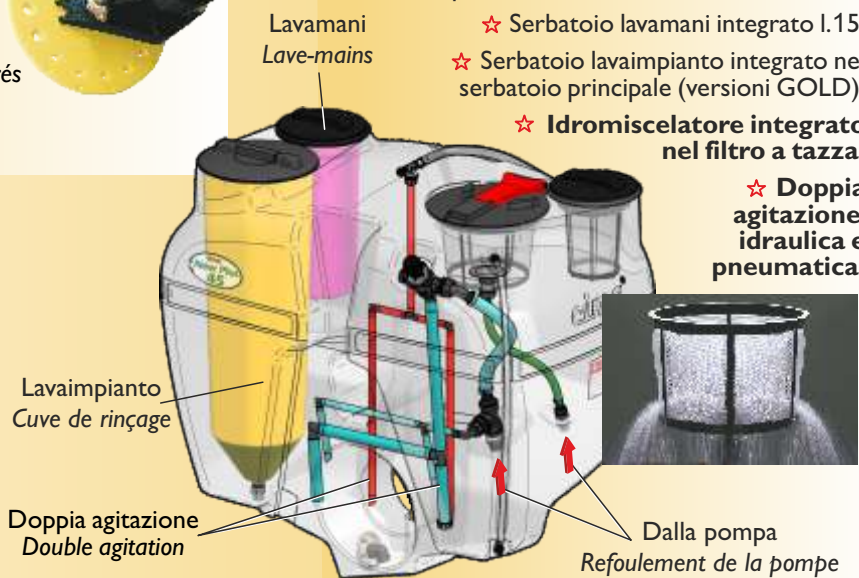

☆ Réservoir en polyéthylène rotomoulé. Large ouverture (Ø 360) avec couvercle à charnière, jauge graduée.

☆ Réservoir lave-mains intégré de 15 litres.

☆ Cuve de rinçage intégrée dans le réservoir principal (versions GOLD).

☆ **Tamis mélangeur intégré.**

☆ **Double agitation, hydro-pneumatique.**

New Plus 42 - 45



- ★ Telaio in acciaio, verniciatura elettrostatica con polvere poliestere e predisposto per applicare coppia ruote.
- ★ Cerchio di protezione delle testate.
- ★ Ventola centrifuga chiusa ad alta pressione, in acciaio, con disinnesto; carter in polietilene rotazionale.
- ★ Controllo dal posto operatore dell'erogazione con due elettrovalvole.



★ Châssis en acier avec peinture polyester électrostatique et adapté pour l'installation d'une paire de roues.

★ Pare-chocs à protection des équipements.

★ Turbine centrifuge fermée haute pression, en acier, débrayable dans volute en polyéthylène rotomoulée.

★ Contrôle du débit à télécommande électrique depuis le poste de conduite.



★ Regolatore di pressione manuale (a comando elettrico dal posto operatore a richiesta).

★ Manometro (ø100) ben visibile dal posto operatore.

★ Filtro di grande portata: 240 l/min.



★ Régulateur de pression manuel (en option télécommande électrique depuis le poste de conduite).

★ Manomètre (ø100), bien visible depuis le poste de conduite.

★ Filtre à grand débit: 240 l/mn.

★ **La pompa centrifuga** di fabbricazione C.I.M.A. (senza membrane e valvole) costruita in materiale anticorrosivo è esente da manutenzione. La cinghia di trasmissione 3V è dotata di tenditore automatico.



★ **La pompe centrifuge** fabrication C.I.M.A. (sans membranes et clapets) produite en matériel anti-corrosion est fiable et sans entretien. Sa courroie de transmission 3V est équipée d'un tendeur automatique.

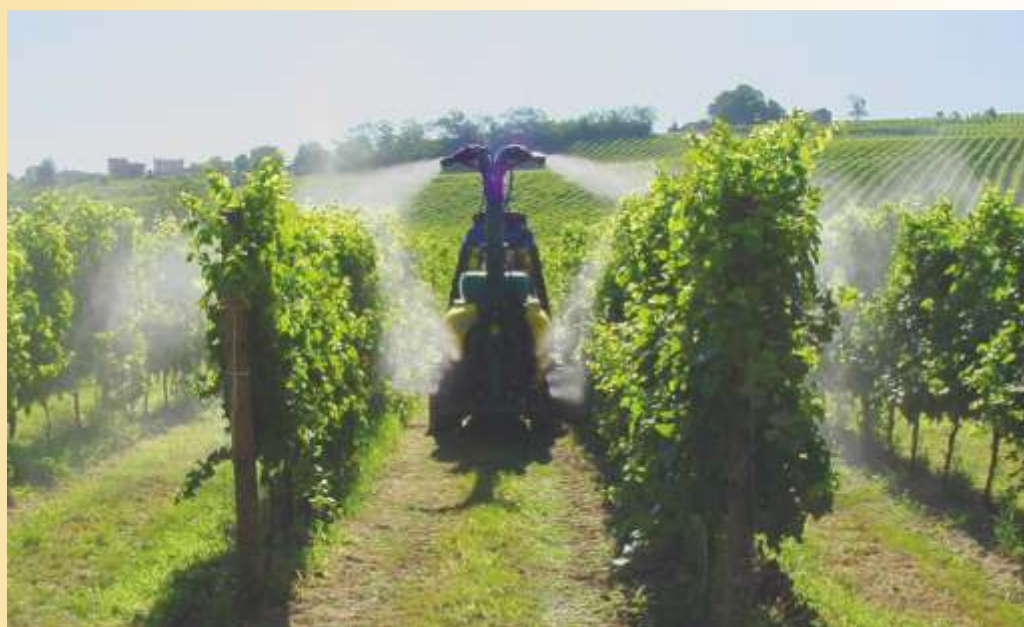

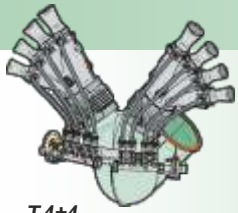
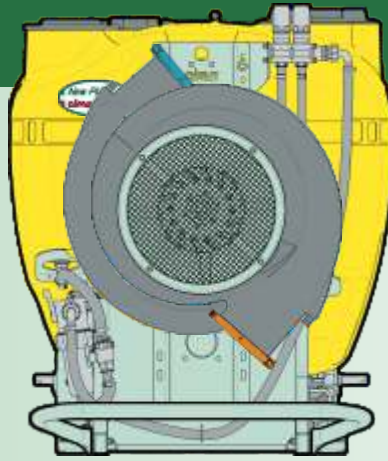

T.4+4
N.Plus 42 (T.4+4.42P)
N.Plus 45 (T.4+4.45P)

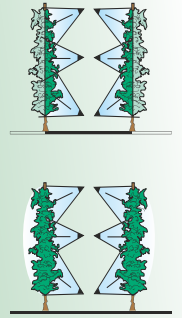
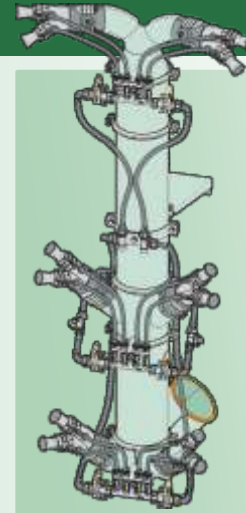
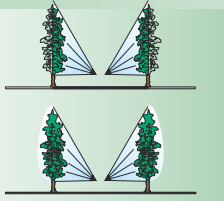

T.6M
N.Plus 42 (T.6M2D.42P)
N.Plus 45 (T.6M2D.45P)

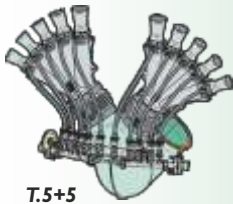

T.5+5
N.Plus 42 (T.5+5.42P)
N.Plus 45 (T.5+5.45P)

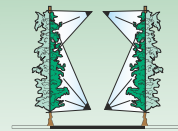
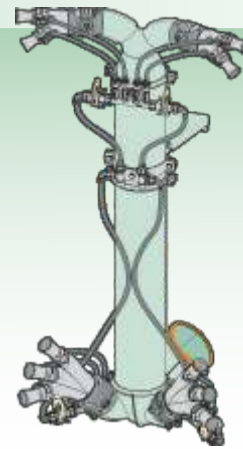
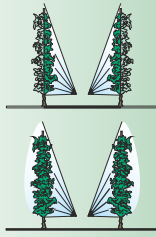

T.4M
N.Plus 42 (T.4M.42P)
N.Plus 45 (T.4M.45P)

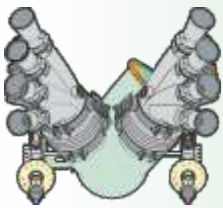

STRASBURGO - STRASBOURG
N.Plus 42 (T.ST4.42P)
N.Plus 45 (T.ST4.45P)

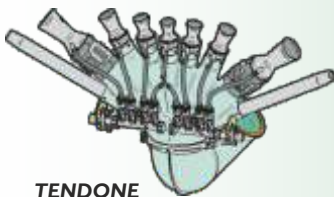
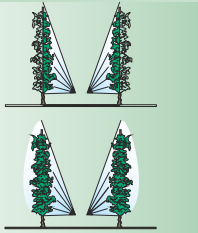

TENDONE
N.Plus 42 (T.TND.42P)
N.Plus 45 (T.TND.45P)

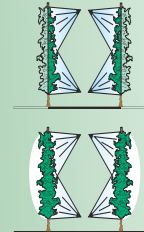
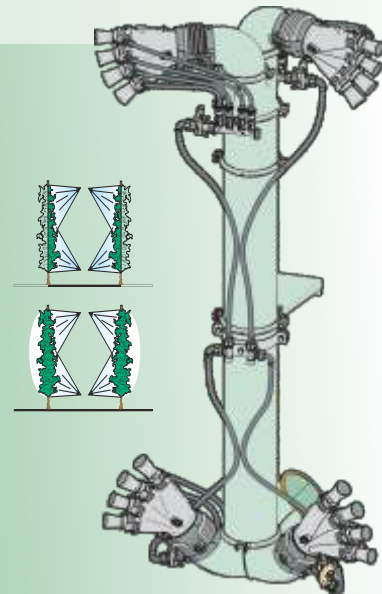
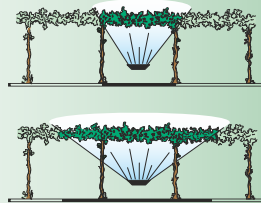

TC.2M2M
N.Plus 45 (TC.2M2M.45P)



2 VENTAGLI - 2 ÉVENTAILS
N.Plus 42-45 (T.2V3S.45P)

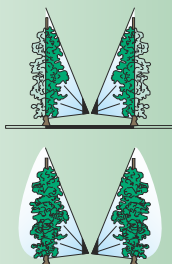

TESTATE -

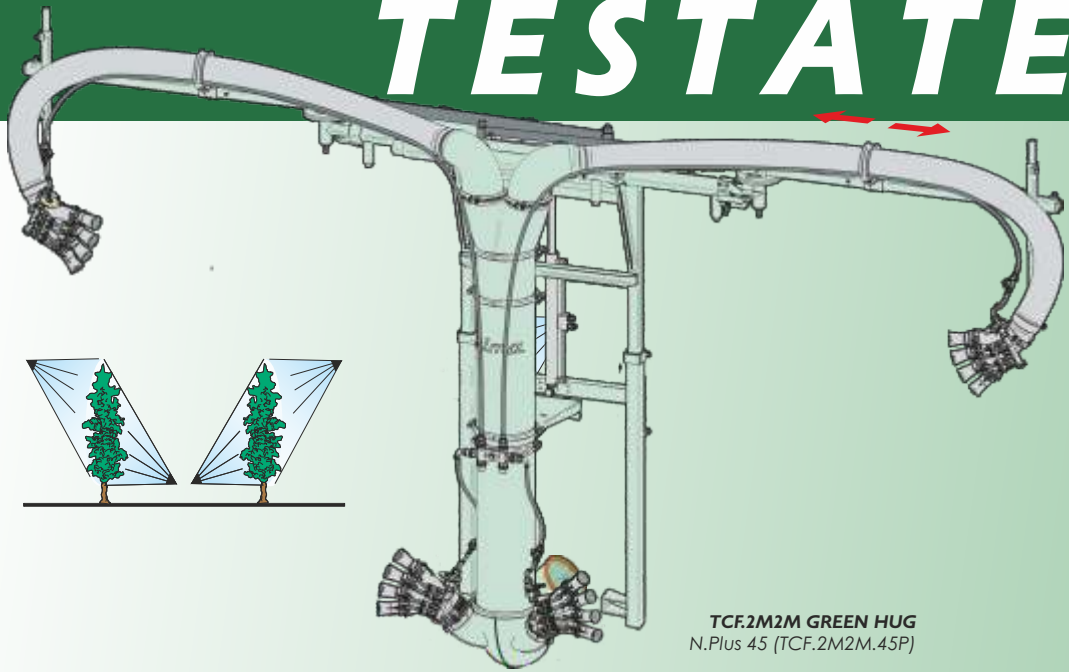

TCF.2M2M GREEN HUG
N.Plus 45 (TCF.2M2M.45P)

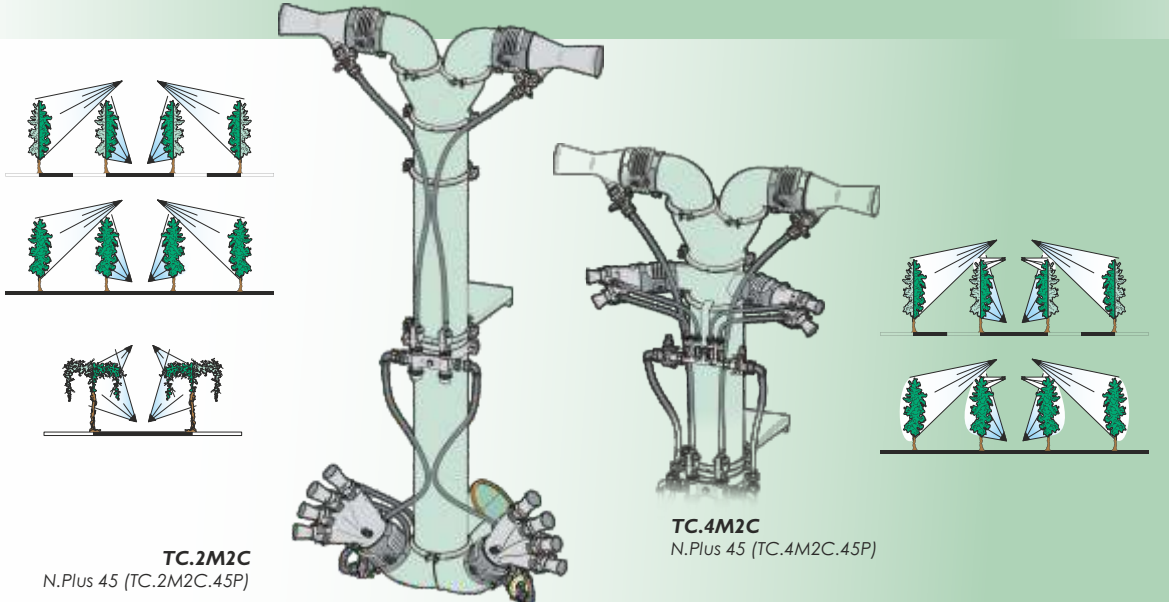

TC.4M2C
N.Plus 45 (TC.4M2C.45P)

TC.2M2C
N.Plus 45 (TC.2M2C.45P)

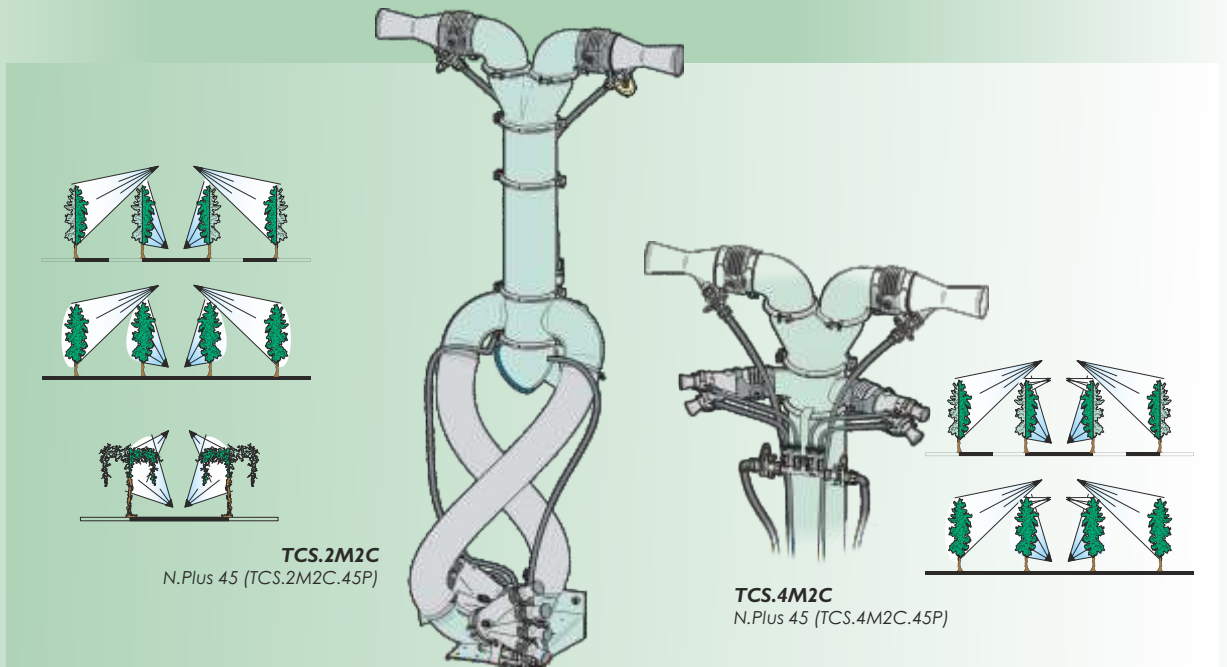

TCS.4M2C
N.Plus 45 (TCS.4M2C.45P)

TCS.2M2C
N.Plus 45 (TCS.2M2C.45P)

EQUIPEMENTS DE

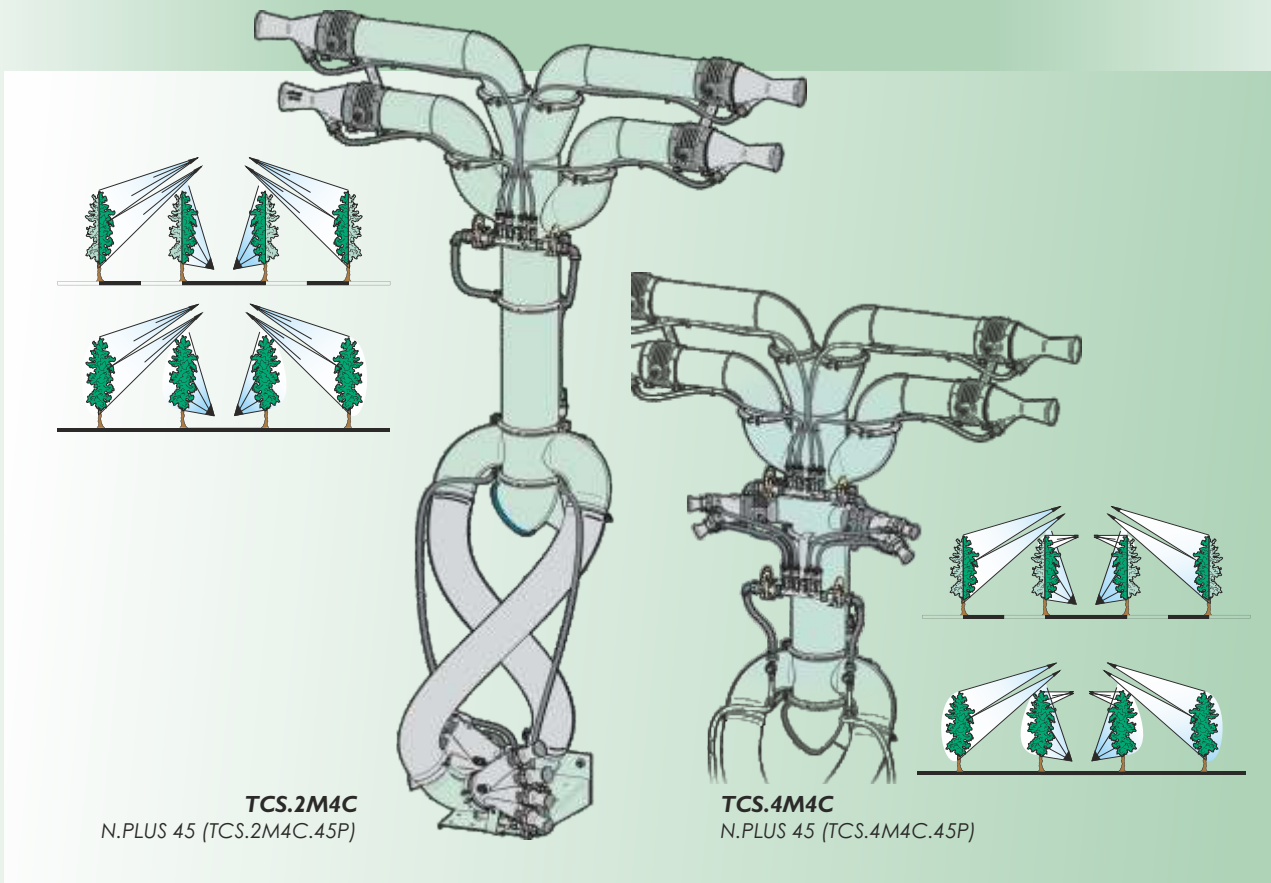
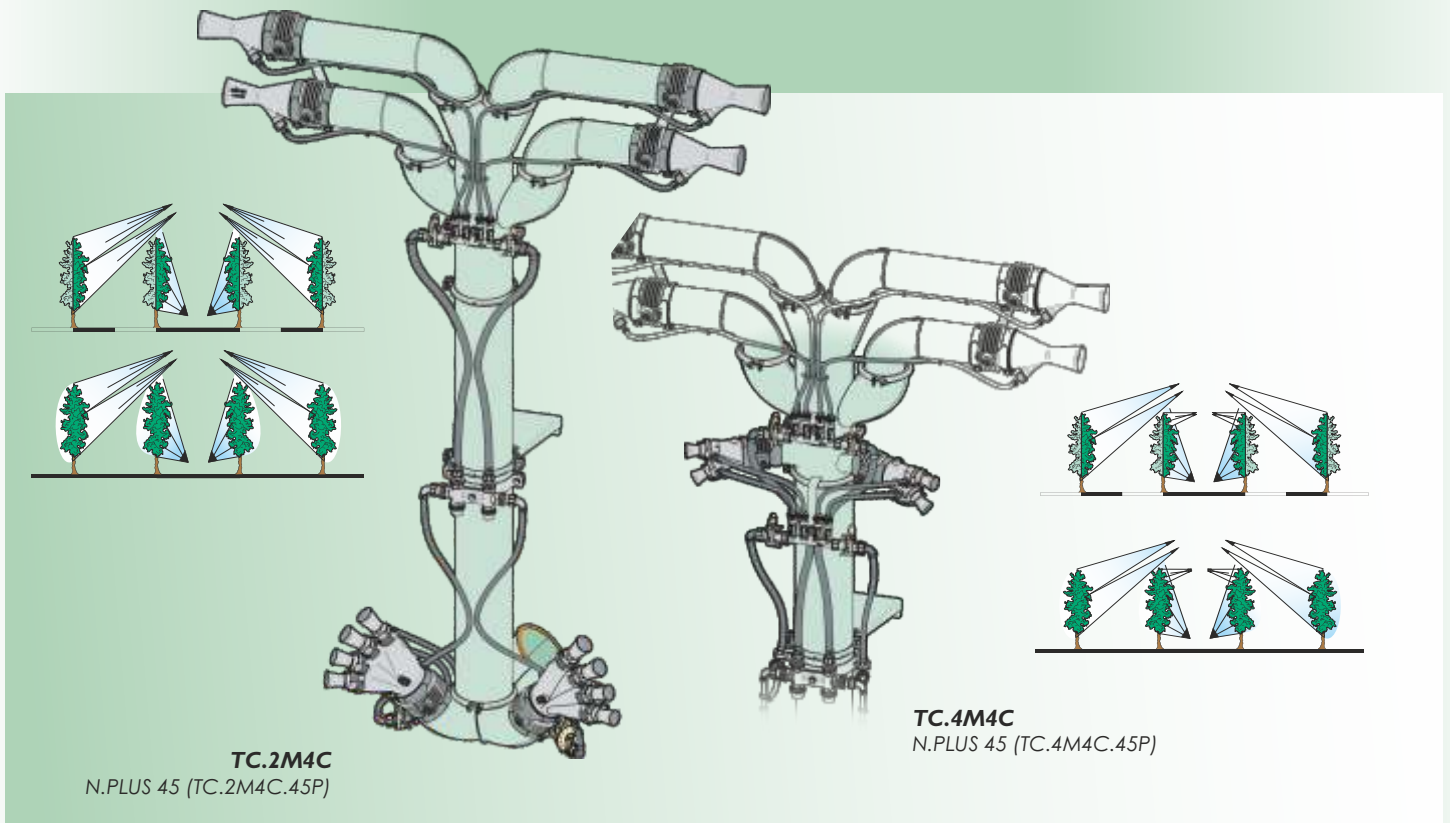

DISTRIBUTIONS

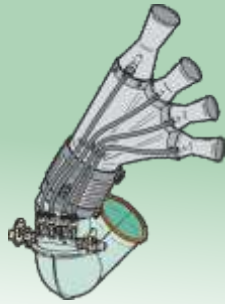

OLIVO - OLIVIER
N.Plus 42 (T.OL.42P)
N.Plus 45 (T.OL.45P)

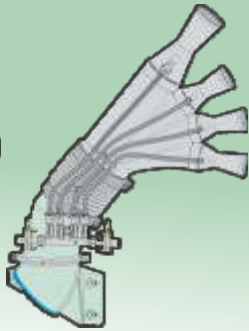

OLIVO - OLIVIER
N.Plus 42 (T.OL.045.42)
N.Plus 45 (T.OL.045.45)

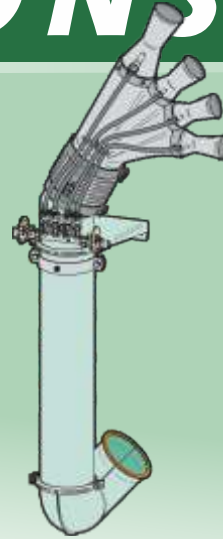
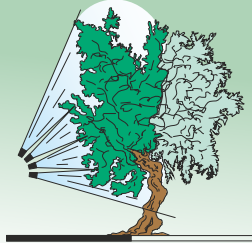

OLIVO - OLIVIER
N.Plus 42 (T.OL.P08.42)
N.Plus 45 (T.OL.P08.45)

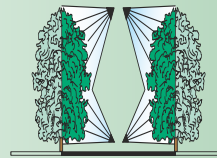
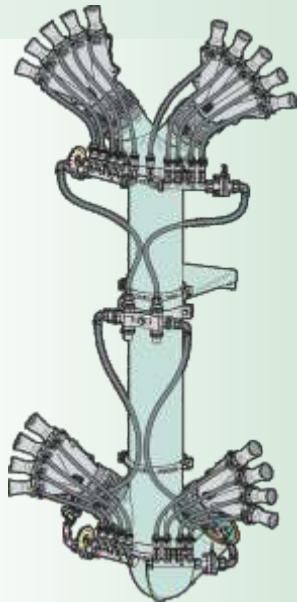
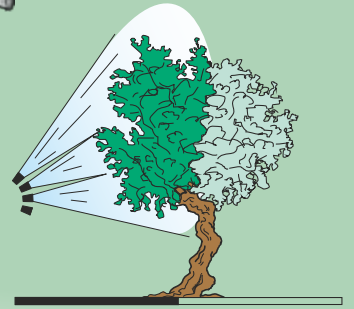

CAFFÈ - CAFÉ
Plus 45 (T.CA.45P)

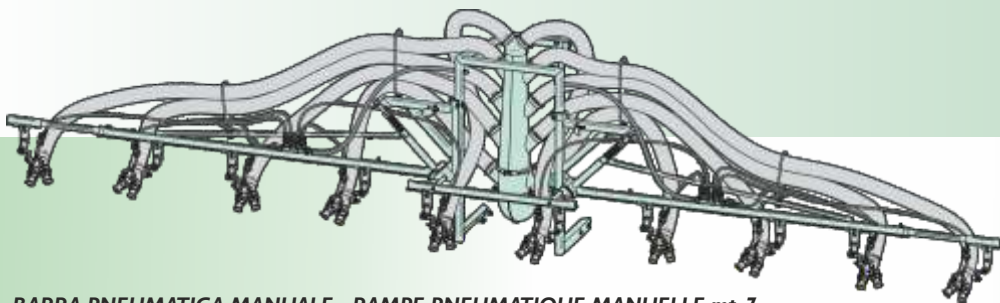

BARRA PNEUMATICA MANUALE - RAMPE PNEUMATIQUE MANUELLE mt. 7
N.Plus 45 (BM10.2.66.45)

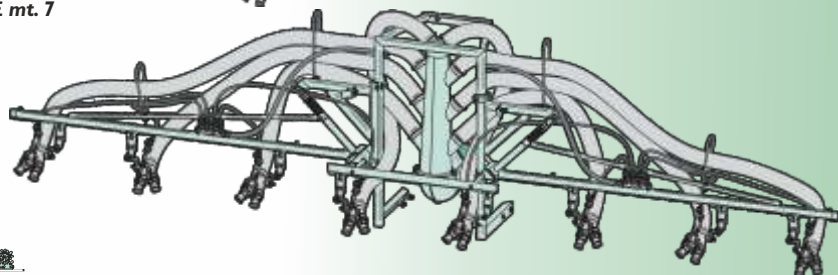

BARRA PNEUMATICA MANUALE - RAMPE PNEUMATIQUE MANUELLE mt. 5
N.Plus 42 (BM08.2.66.42)
N.Plus 45 (BM08.2.66.45)



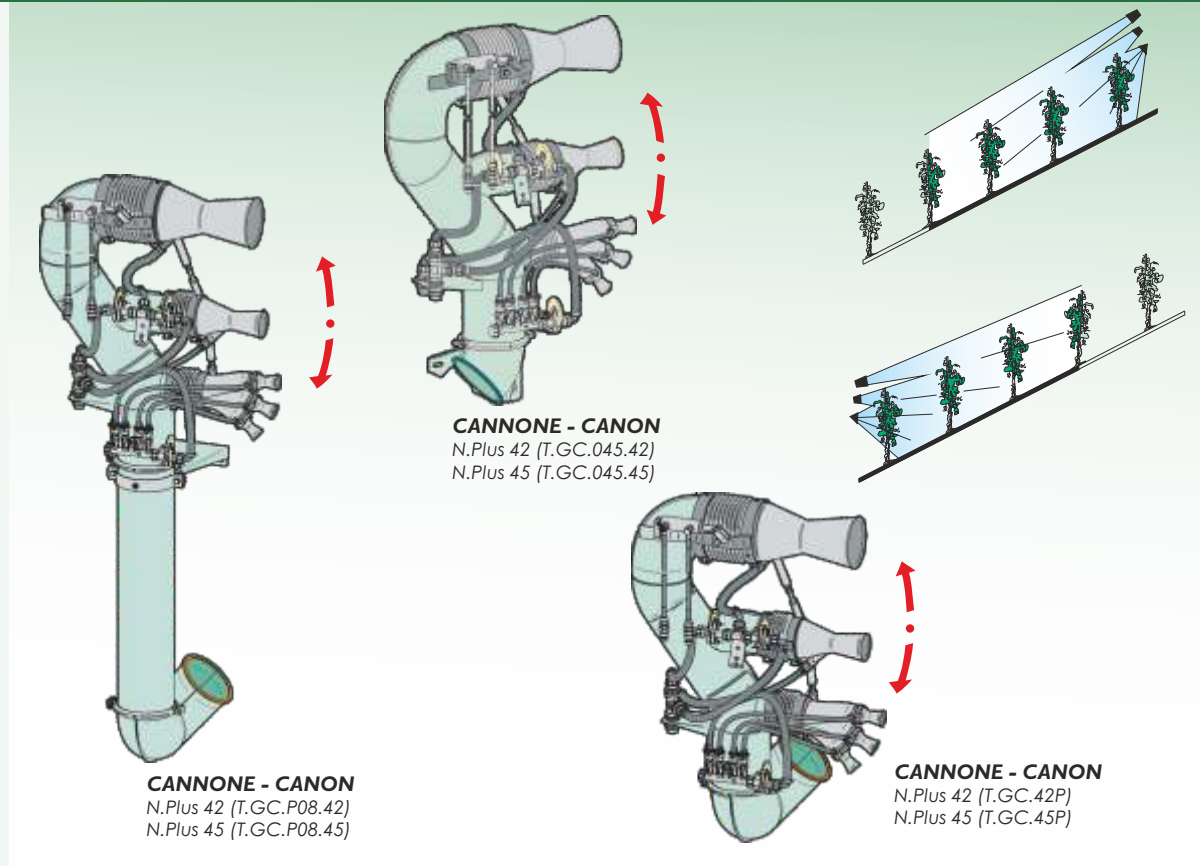

CANNONE - CANON
N.Plus 42 (T.GC.P08.42)
N.Plus 45 (T.GC.P08.45)

CANNONE - CANON
N.Plus 42 (T.GC.045.42)
N.Plus 45 (T.GC.045.45)

CANNONE - CANON
N.Plus 42 (T.GC.42P)
N.Plus 45 (T.GC.45P)

ACCESSORI - ACCESSOIRES

KIT PISTONI IDRAULICI KIT VERRINS HYDRAULIQUES

disponibile per:
disponible pour:
T. 4+4
T. 5+5
T.OL

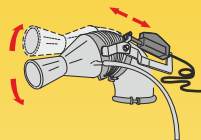
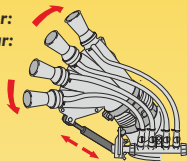

KIT PISTONI ELETTRICI (solo cannoni superiori)

KIT VERRINS ÉLECTRIQUES (seulement pour les canons supérieurs)



GRUPPO 2 ELETTROVALVOLE SUPPLEMENTARI GROUPE 2 ELECTROSOUPEPE ADDITIONNEL

N.Plus 45-50 (D.4E.P11)

REGOLATORE ELETTRICO PRESSIONE VANNE RÉGLAGE ÉLECTRIQUE DE LA PRESSION

N. Plus 42-45 (D.V.P01)

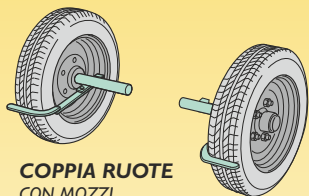

COPPIA RUOTE CON MOZZI PAIR OF WHEELS WITH HUBS

N.Plus 42-45 (T.CPP.RT.01)

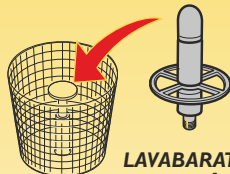

LAVABARATTOLI LAVE-BOÎTES (KIT.LAV.BOX)



KIT EASY FARM KIT EASY FARM

N.Plus 45-50 (K.EASYFARM.01)

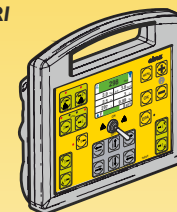

E.P.A 2.0 Erogazione Proporzionale Avanzamento Débit Proportionnel à l'Avancement

N.Plus 42-45 (EPA.P11)

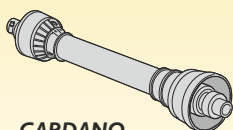

CARDANO CARDAN

N. Plus 42 (KHP.040.090)
N. Plus 45 (KHP.050.090)

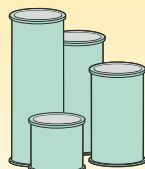

PROLUNGHE - RALLONGES

N.Plus 42-45 D-175mm
200mm (X02.186.000) - 400mm (X02.187.000)
600mm (X02.188.000) - 800mm (X02.189.000)



COLLARE - COLLIER D-175mm (X05.616.000)

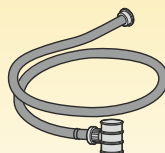

TUBAZIONE RIEMPIMENTO TUBULURE DE REMPLISSAGE

N. Plus 42-45 (TUBAZ.RIEMP)

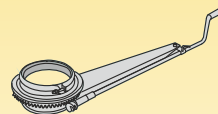

GIREVOLE MANUALE PIVOTANT MANUEL

N.Plus 42-45 (T.GIR.M.175P)

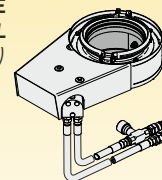





GIREVOLE IDRAULICO PIVOTANT HYDRAULIQUE

N.Plus 42-45 (T.GIR.I.175P)

Alcuni accessori sono forniti di serie in certi paesi - Certains accessoires sont fournis de série dans certains pays

INFORMAZIONI TECNICHE CARACTERISTIQUES TECHNIQUES

		New Plus 42	New Plus 45
	TRATTRICE	potenza richiesta 18 kW - 25 CV	potenza richiesta 33 kW - 45 CV
	TRACTEUR	puissance demandée 18 kW - 25 CV	puissance demandée 33 kW - 45 CV
	ATOMIZZATORE	potenza assorbita 13 kW - 18 CV	potenza assorbita 17 kW - 23 CV
	PNEUMATIQUE	puissance absorbée 13 kW - 18 CV	puissance absorbée 17 kW - 23 CV
	VENTOLA	radiale in acciaio chiusa D.450 mm 4000 giri/min. portata aria: 4000 m ³ /h velocità aria: 228 m/s	radiale in acciaio chiusa 450 mm 4500 giri/min. portata aria: 5400 m ³ /h velocità aria: 188 m/s
	TURBINE	diamètre 450 mm, fermée, en acier 4000 t/mn débit d'air: 4000 m ³ /h - vitesse d'air: 228 m/s	diamètre 450 mm, fermée, en acier 4500 t/mn débit d'air: 5400 m ³ /h - vitesse d'air: 188 m/s
	POMPA	centrifuga di alimentazione e agitazione CIMA CD 32 - 4000 giri/min. portata 120 l/min. - pressione massima 4,5 kg/cm ²	centrifuga di alimentazione e agitazione CIMA CD 32 - 4250 giri/min. portata 140 l/min. - pressione massima 4,5 kg/cm ²
	POMPE	centrifuge CIMA CD 32 - 4000 t/mn débit 120 l/mn - pression max 4,5 kg/cm ²	centrifuge CIMA CD 32 - 4250 t/mn débit 140 l/mn - pression max 4,5 kg/cm ²

Valori suscettibili di variazioni in funzione del dispositivo di distribuzione utilizzato
Valeurs indicatives qui peuvent changer en fonction de l'équipement de distribution utilisé.

DIMENSIONI E PESO - DIMENSIONS ET POIDS

		New Plus 42-45		New Plus Gold 42-45	
		I. 300	I. 400	I. 300	I. 400
	LUNGHEZZA	144-162 cm	144-162 cm	144-162 cm	144-162 cm
	LONGUEUR				
	LARGHEZZA	96 cm	112 cm	96 cm	112 cm
	LARGEUR				
	ALTEZZA	119 cm	122 cm	127 cm	130 cm
	HAUTEUR				
	PESO	42: 208 kg	42: 211 kg	42: 216 kg	42: 219 kg
	POIDS	45: 210 kg	45: 213 kg	45: 218 kg	45: 221 kg

Il peso indicato è calcolato a vuoto SENZA il dispositivo di distribuzione e SENZA gli accessori eventualmente installati.
I valori sono riportati a titolo indicativo e possono variare secondo la configurazione della macchina
Le poids indiqué est calculé à vide SANS le dispositif de distribution et SANS les accessoires installés.
Les valeurs sont à titre indicatif et peuvent varier suivant la configuration de la machine

Nei paesi dell'Unione Europea le nostre attrezzature sono conformi alla Direttiva Europea "Macchine"; negli altri paesi sono conformi alle norme di sicurezza in vigore in quei paesi.



Dans les pays de l'Union Européenne, nos équipements sont conformes à la Directive Européenne "Machines"; dans les autres pays ils sont conformes aux prescriptions de sécurité en vigueur dans ces pays.

cima[®]



RIVENDITORE AUTORIZZATO - CONCESSIONAIRE

Loc. Molino Quaroni n.7, Montù Beccaria - PV - (ITALY)
Tel. +39.0385.246636 - www.cima.it



10/2022