



cima[®]

ATOMIZZATORI-IMPOLVERATORI



New Plus 50

**ATOMIZZATORI PNEUMATICI A BASSO VOLUME
PNEUMATIC LOW VOLUME SPRAYERS**

Atomizzatori - Sprayers



☆ Ampia scelta di testate di distribuzione, tutte dotate del nuovo sistema anti-sgocciolamento (brev. N° 1745689) e di dispositivi di diffusione (mani e/o cannoni) di diverse dimensioni, **adattabili in altezza, orientabili ed intercambiabili** per garantire, su tutte le tipologie di colture, un'eccellente copertura e penetrazione nella vegetazione.



☆ Broad range of sprayheads, all equipped with the new anti-drip system (patent Nr. 1745689). Sprayheads' distribution devices (hands or cannons) are available in different sizes and heights, they can be **adjustable and interchangeable** to guarantee a better spray penetration through the canopy and a complete coverage on any type of crop.

☆ **Regolatori a disco rotante** con 15 fori calibrati (brev. N° 23238), sostituiscono il sistema a pastiglie. **Erogazione da 70 a 3400 litri/ora**



☆ **Rotating calibration discs**, 15 positions (patent Nr. 23238), very easy to adjust: **delivery from 70 to 3400 l/h**

☆ **Trasmissione a cinghia poly-V** che assorbe le sollecitazioni. **Funzionamento per oltre 5000 ore.** Il tenditore automatico evita lo slittamento e quindi l'usura. La qualità della polverizzazione resta inalterata nel tempo.

☆ **Ruota libera di sicurezza** per arresto improvviso.

☆ **Poly-V belt drive**, to absorb any stress. **Long life belt - over 5000 hours.** The automatic tensioner keeps tension constant on the belt, avoiding slipping and wear. High quality spray atomization after several years of use.

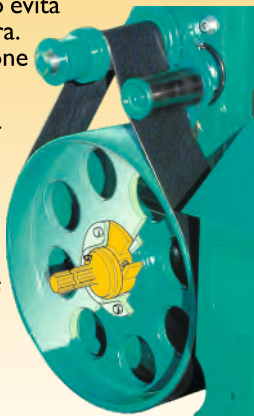

☆ **Overrunning clutch - Safety stop device** in the event the PTO is suddenly stopped.

☆ Serbatoio in polietilene rotazionale, apertura di riempimento di grandi dimensioni (ø360) con coperchio a cerniera, indicatore di livello.

☆ Serbatoio lavamani integrato l. 15.

☆ Serbatoio lavaimpianto integrato nel serbatoio principale (versioni GOLD).

☆ **Idromiscelatore integrato nel filtro a tazza.**

☆ **Doppia agitazione, idraulica e pneumatica.**

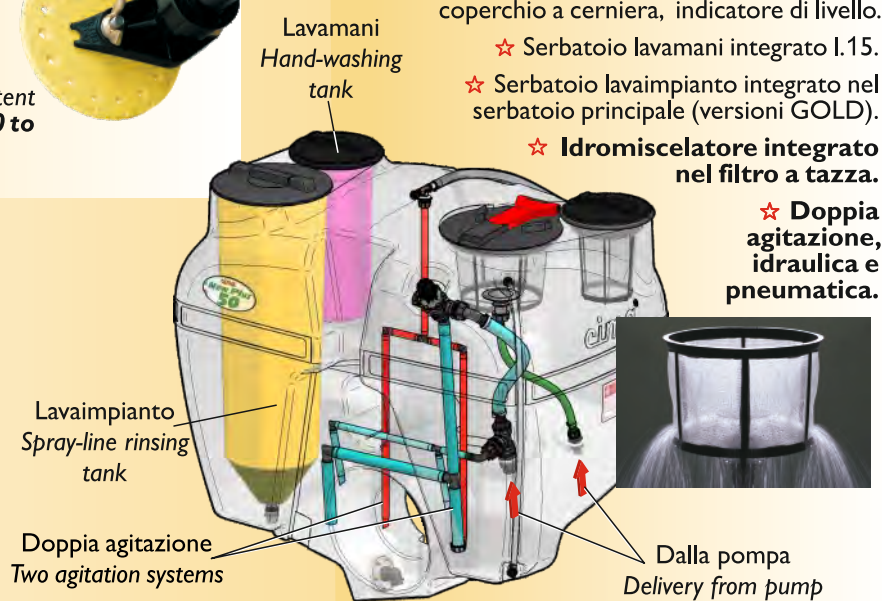

☆ Polyethylene tank. Large filling opening (ø360) with hinged lid and graduated level indicator.

☆ 15 litres fresh water tank included.

☆ **Hydraulic pre-mixer incorporated within the basket filter.**

☆ **Two agitation systems, liquid and air.**

New Plus 50



- ★ Telaio in acciaio, verniciatura elettrostatica con polvere poliestere e predisposto per applicare coppia ruote.
- ★ Cerchio di protezione delle testate.
- ★ Ventola centrifuga chiusa ad alta pressione, in acciaio, con disinnesto; carter in polietilene rotazionale.
- ★ Controllo dal posto operatore dell'erogazione con due elettrovalvole.



- ★ Steel frame, electrostatic painted with polyester powder designed for installing optional support wheels.
- ★ Sprayhead bumper guard.
 - ★ Steel high pressure radial fan (fan clutch in option), polyethylene fan housing.
 - ★ Spraying ON/OFF control by remote control electro-valves from tractor seat.



- ★ Regolatore di pressione manuale (a comando elettrico dal posto operatore a richiesta).
- ★ Manometro (ø100) ben visibile dal posto operatore.
- ★ Filtro di grande portata: 240 l/min.



- ★ Pressure regulator with manual control (optional electro-control from tractor seat).



- ★ 100mm pressure gauge, clearly visible from tractor seat.



- ★ Large capacity delivery filter : 240 l/min.

- ★ La pompa centrifuga di fabbricazione C.I.M.A. (senza membrane e valvole) costruita in materiale anticorrosivo è esente da manutenzione. La cinghia di trasmissione 3V è dotata di tenditore automatico.



- ★ C.I.M.A.'s centrifugal pump (no diaphragms or valves), is made of anticorrosive material and **does not require any maintenance**. The pump is driven by a 3-V belt equipped with an automatic tensioner.



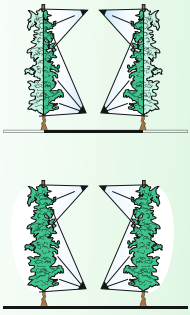
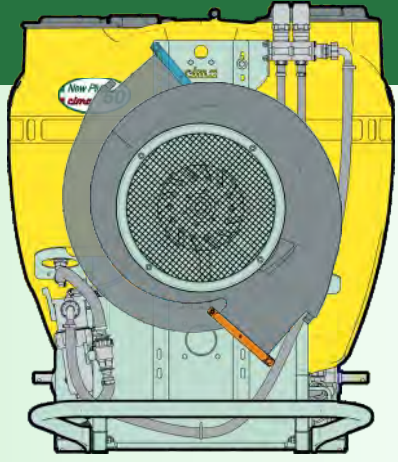

T.4M
N.Plus 50 (T.4M.50P)

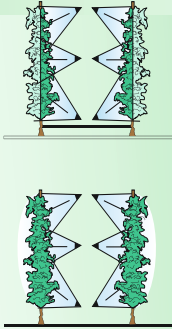
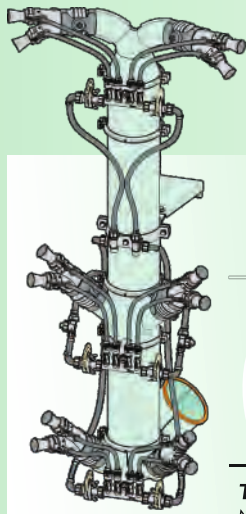
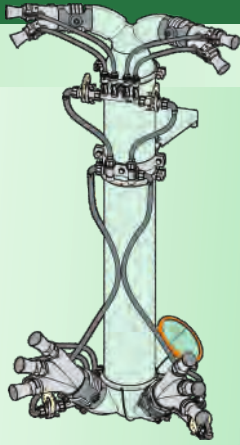

T.6M
N.Plus 50 (T.6M2D.50P)

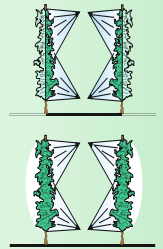
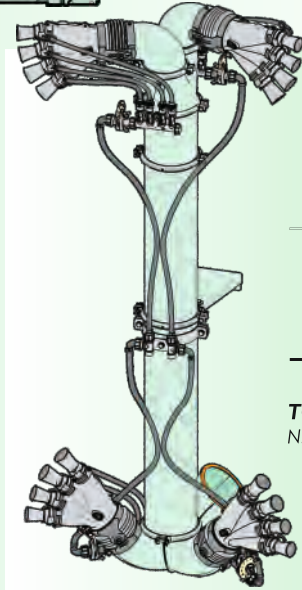

TC.2M2M
N.Plus 50 (TC.2M2M.50P)

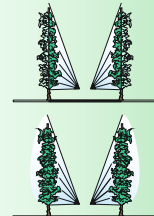
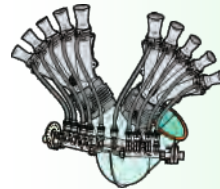

T.5+5
N.Plus 50 (T.5+5.50P)

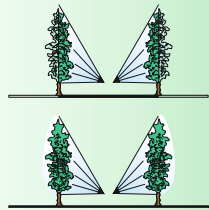

T.4+4
N.Plus 50 (T.4+4.50P)

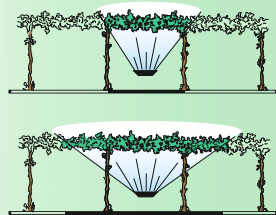

TENDONE
N.Plus 50 (T.TND.50P)

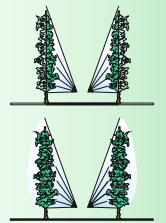
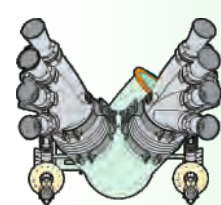

STRASBURGO - STRASBOURG
N.Plus 50 (T.ST4.50P)

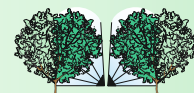

2 VENTAGLI - 2 FISHTAILS
N.Plus 50 (T.2V4.50P)
(T.2V3L.50P)

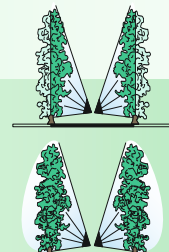

TESTATE -

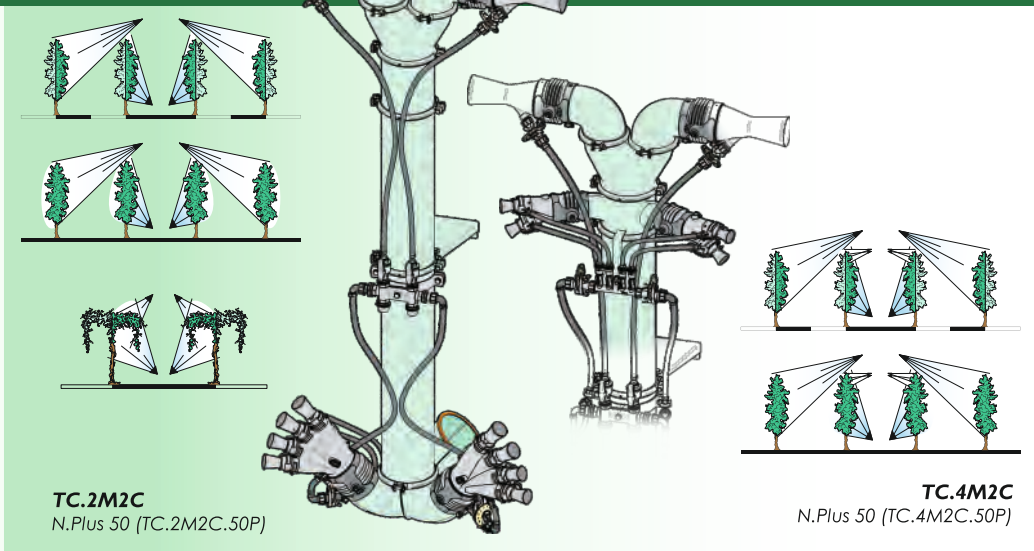

TC.2M2C
N.Plus 50 (TC.2M2C.50P)

TC.4M2C
N.Plus 50 (TC.4M2C.50P)

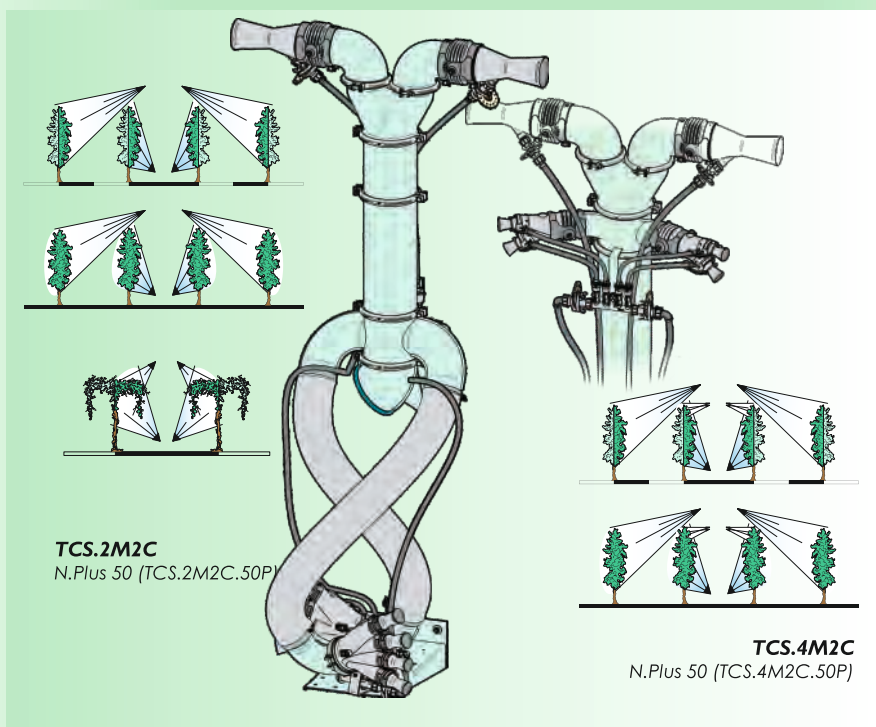

TCS.2M2C
N.Plus 50 (TCS.2M2C.50P)

TCS.4M2C
N.Plus 50 (TCS.4M2C.50P)

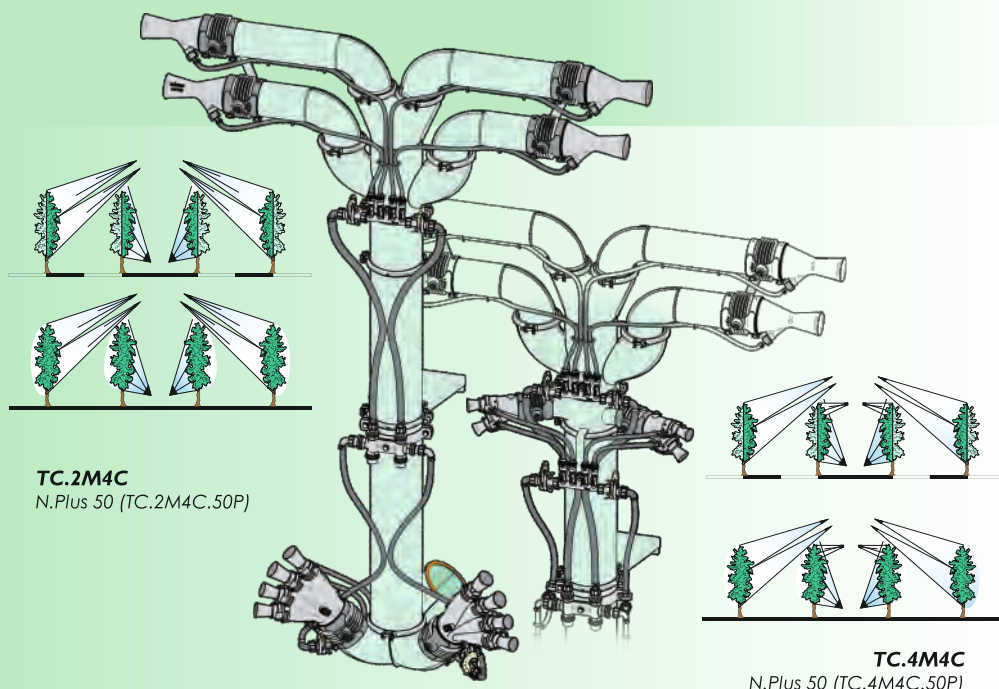

TC.2M4C
N.Plus 50 (TC.2M4C.50P)

TC.4M4C
N.Plus 50 (TC.4M4C.50P)

SPRAYHEADS

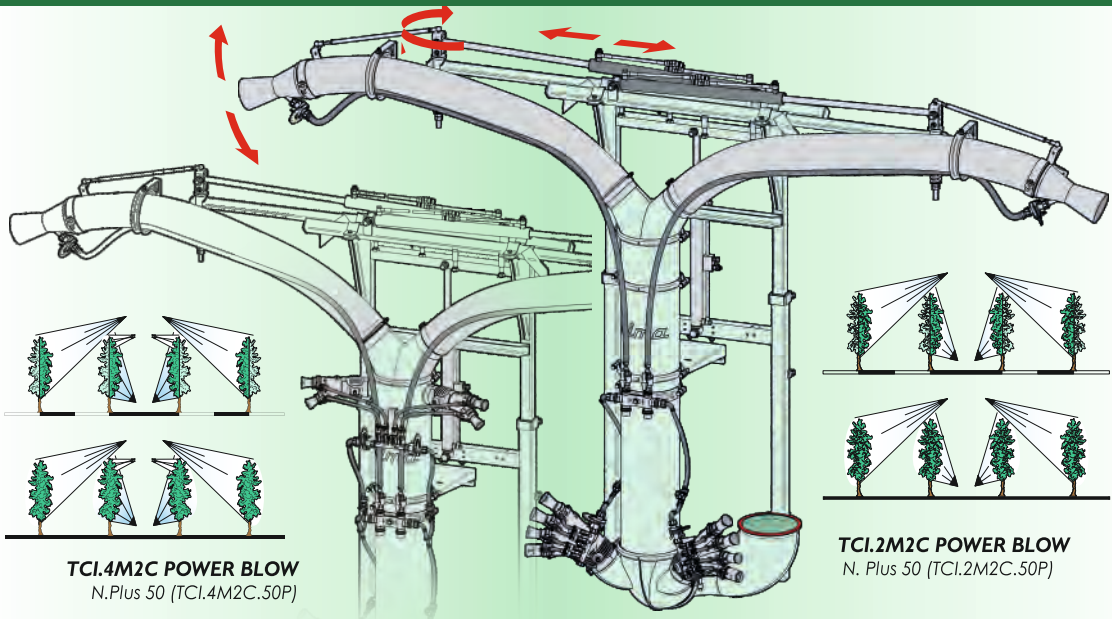

TCI.4M2C POWER BLOW
N.Plus 50 (TCI.4M2C.50P)

TCI.2M2C POWER BLOW
N. Plus 50 (TCI.2M2C.50P)

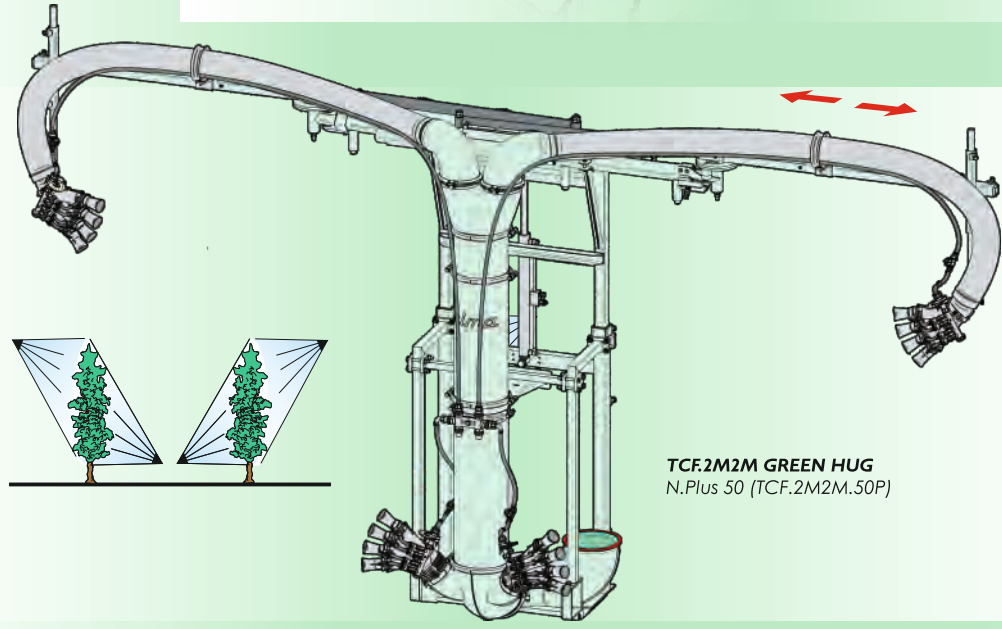

TCF.2M2M GREEN HUG
N.Plus 50 (TCF.2M2M.50P)

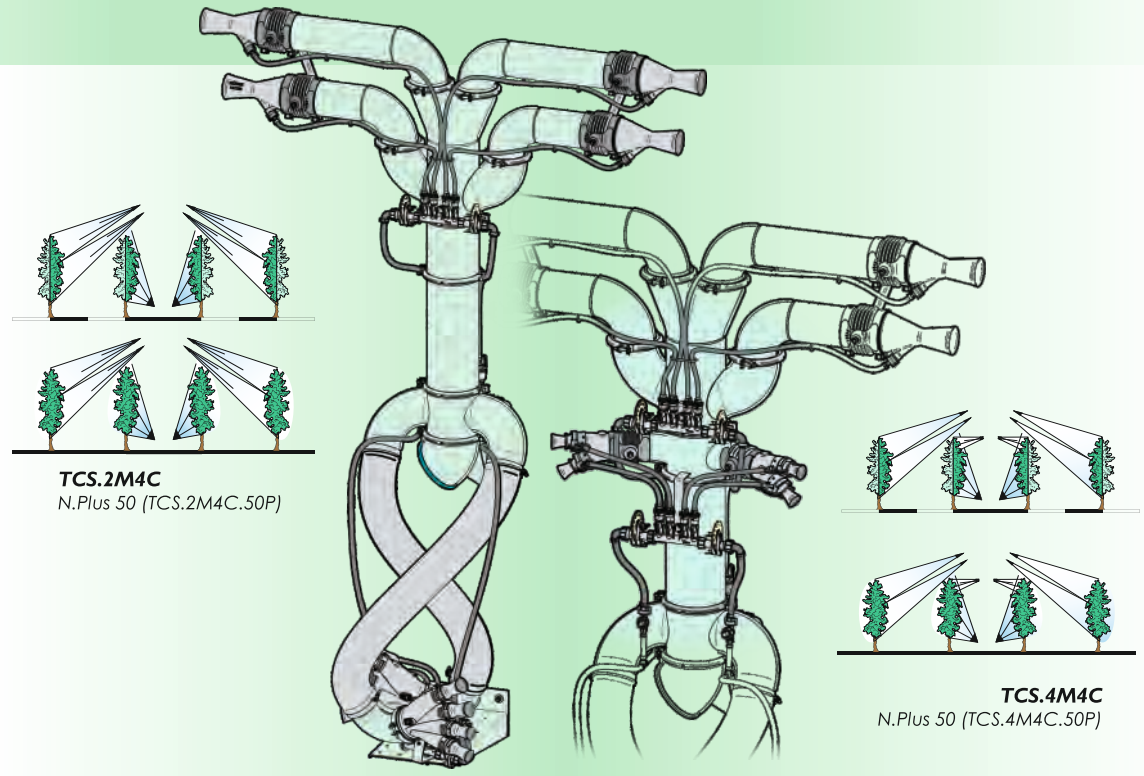

TCS.2M4C
N.Plus 50 (TCS.2M4C.50P)

TCS.4M4C
N.Plus 50 (TCS.4M4C.50P)

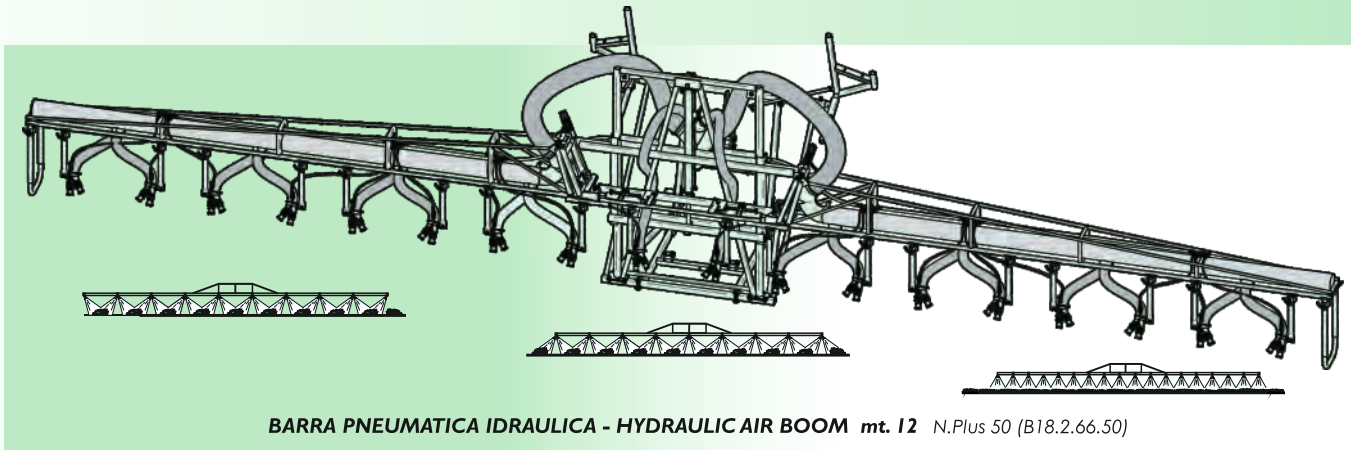
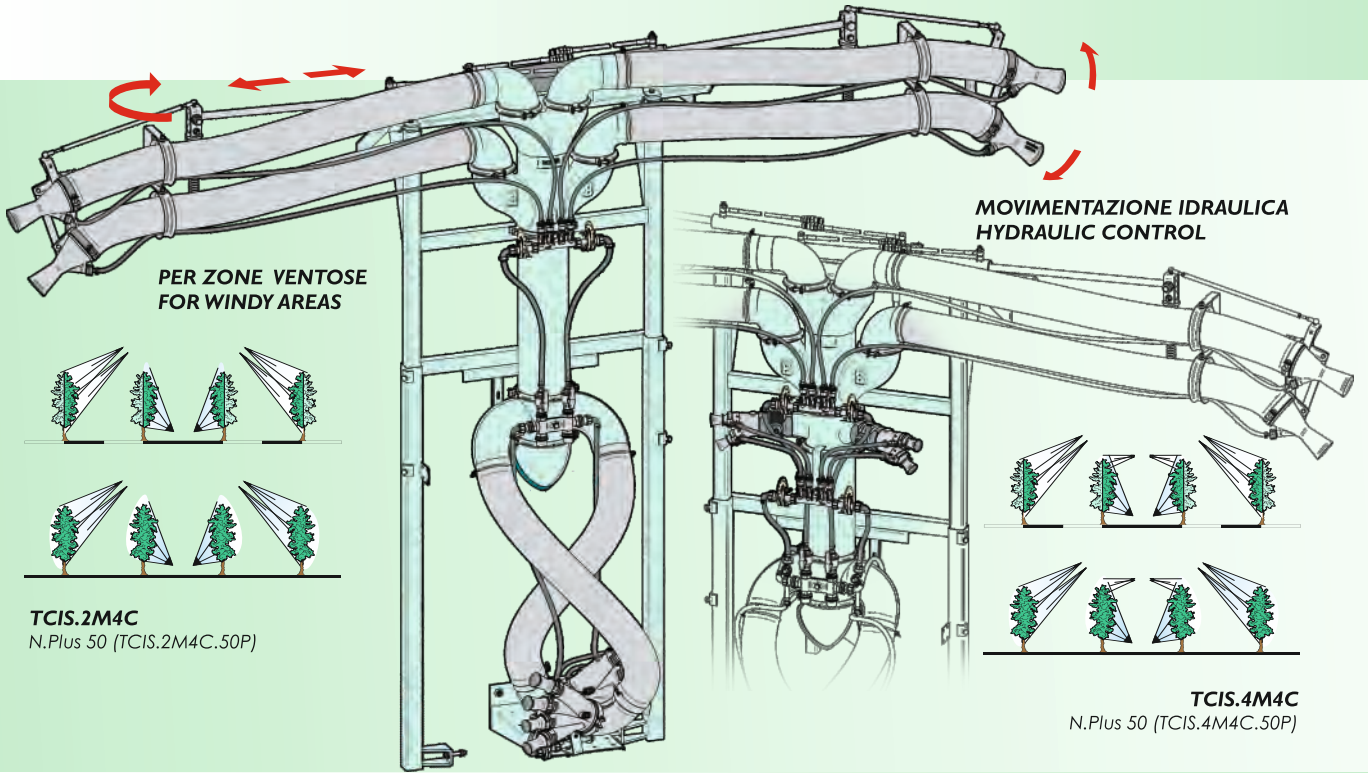
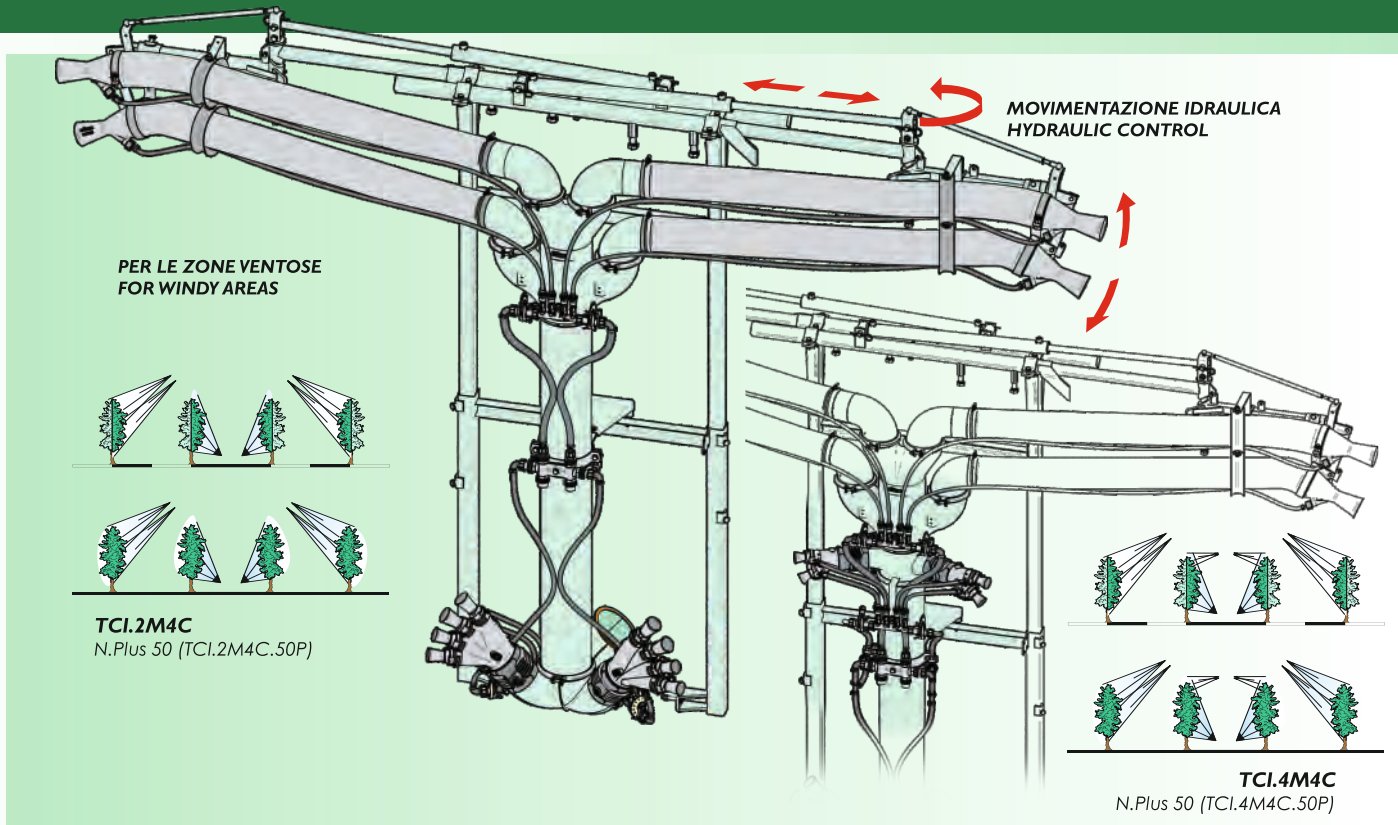

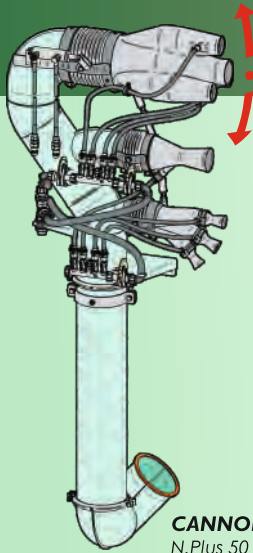

CANNONE - CANNON
N.Plus 50 (T.GC.P08.50)

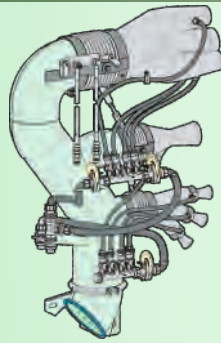

CANNONE - CANNON
N.Plus 50 (T.GC.045.50)

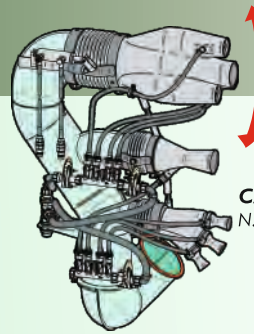

CANNONE - CANNON
N.Plus 50 (T.GC.50P)

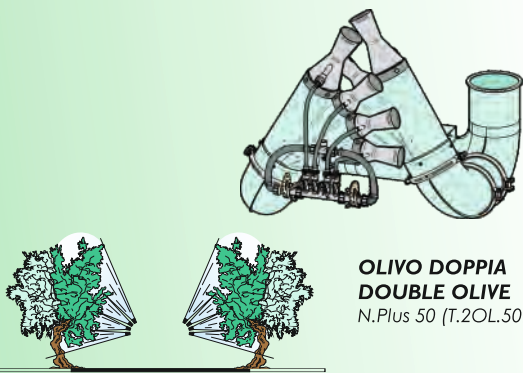
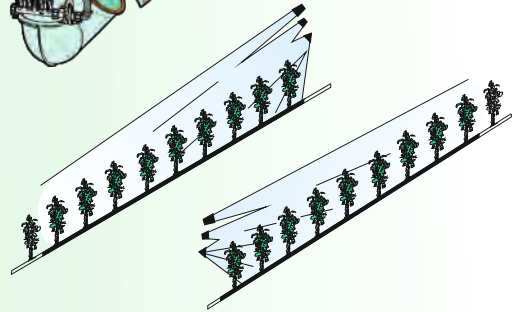

**OLIVO DOPPIA
DOUBLE OLIVE**
N.Plus 50 (T.2OL.50P)

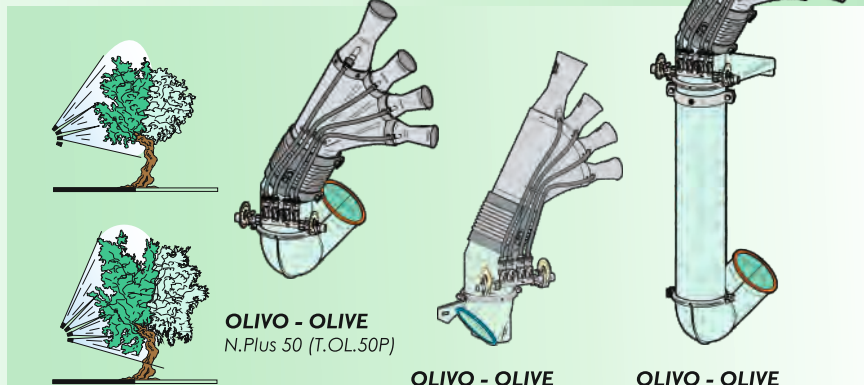

OLIVO - OLIVE
N.Plus 50 (T.OL.50P)

OLIVO - OLIVE
N.Plus 50 (T.OL.045.50)

OLIVO - OLIVE
N.Plus 50 (T.OL.P08.50)

ACCESSORI - OPTIONAL DEVICES

KIT PISTONI IDRAULICI HYDRAULIC-CYLINDER KIT

disponibile per:
available for:
T.4+4
T.5+5
T.OL

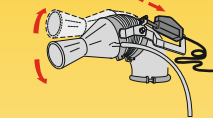
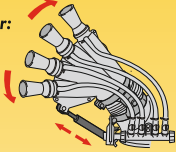

KIT PISTONI ELETTRICI
(solo cannoni superiori)
ELECTRO-CYLINDER KIT
(only for upper cannons)

**GRUPPO 2
ELETTOVALVOLE SUPPLEMENTARI**
**2 ADDITIONAL
ELECTROVALVES ASSEMBLY**
N.Plus 50 (D.4E.P11)



REGOLATORE ELETTRICO PRESSIONE
ELECTRICAL PRESSURE REGULATION VALVE
N.PLUS 50 (D.V.P01)

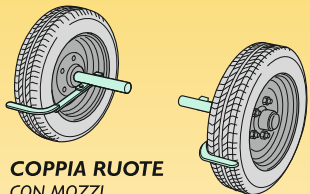

**COPPIA RUOTE
CON MOZZI
PAIR OF WHEELS
WITH HUBS**
N.Plus 50 Lt.400 (T.CPP.RT.01)
Lt.600 (T.CPP.RT.02)

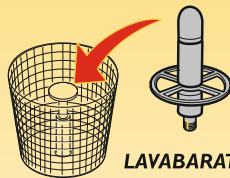

**LAVABARATTOLI
CONTAINER
WASHING DEVICE**
(KIT.LAV.BOX)

**SENSORI ULTRASUONI
ULTRASONIC SENSOR**
N.Plus (D.SU2.EPA.P02)



**KIT EASY FARM
EASY FARM KIT**
N.PLUS 50 (K.EASYFARM.01)

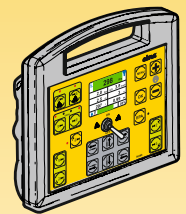

E.P.A 2.0
Erogazione Proporzionale Avanzamento
Delivery Proportional to the Advance
N.PLUS 50 (EPA.P11)



COLLARE - COLLAR
D-175mm (X05.616.000)

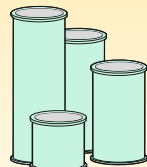

PROLUNGHE - EXTENSIONS
N.Plus 50 D-175mm
200mm (X21.186.000) - 400mm (X21.187.000)
600mm (X21.188.000) - 800mm (X21.189.000)

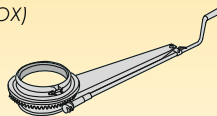

**GIREVOLE MANUALE
MANUAL SWIVELLING DEVICE**
N.Plus 50 (T.GIR.M.175P)

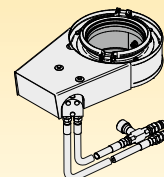

**GIREVOLE IDRAULICO
HYDRAULIC SWIVELLING DEVICE**
N.Plus 50 (T.GIR.I.175P)

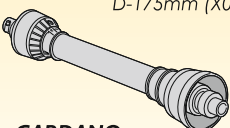



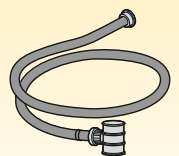

**CARDANO
CARDAN SHAFT**
N.Plus 50 (KHP.060.090)



**TUBAZIONE RIEMPIMENTO
FILLING PIPE**
N.Plus 50 (TUBAZ.RIEMP)

Alcuni accessori sono forniti di serie in certi paesi - Some options are standard supplied in some countries

INFORMAZIONI TECNICHE TECHNICAL INFORMATION

		New Plus 50	
	TRATTRICE	potenza richiesta 48 kW - 65 CV	
	TRACTOR	required power 48 kW - 65 HP	
	ATOMIZZATORE	potenza assorbita 24 kW - 33 CV	
	SPRAYER	absorbed power 24 kW - 33 HP	
	VENTOLA	radiale in acciaio chiusa D.500 mm 4000 giri/min. portata aria: 7550 m ³ /h velocità aria: 175 m/s	
	FAN	500 mm dia. steel closed radial fan - 4000 rpm air delivery 7550 m ³ /h - air speed: 175 m/s	
	POMPA	centrifuga di alimentazione e agitazione CIMA CD 32 - 4250 giri/min. portata 140 l/min. - pressione massima 4,5 kg/cm ²	
	PUMP	centrifugal spray and agitation CIMA CD 32 pump - 4250 rpm 140 l/min. delivery - 4,5 kg/cm ² max pressure	

Valori suscettibili di variazioni in funzione del dispositivo di distribuzione utilizzato
Values can vary according to the used distribution sprayhead

DIMENSIONI E PESO - DIMENSIONS AND WEIGHT

		New Plus 50		New Plus Gold 50	
		I. 400	I. 600	I. 400	I. 600
	LUNGHEZZA	144-162 cm	148-166 cm	144-162 cm	148-166 cm
	LENGTH				
	LARGHEZZA	112 cm	137 cm	112 cm	137 cm
	WIDTH				
	ALTEZZA	122 cm	127 cm	130 cm	135 cm
	HEIGHT				
	PESO	240 kg	255kg	248 kg	263 kg
	WEIGHT				

Il peso indicato è calcolato a vuoto SENZA il dispositivo di distribuzione e SENZA gli accessori eventualmente installati.
I valori sono riportati a titolo indicativo e possono variare secondo la configurazione della macchina.
Weight empty without distribution device and installed accessories.
The value are indicative only, and may vary depending on the configuration of the machine.

Nei paesi dell'Unione Europea le nostre attrezzature sono conformi alla Direttiva Europea "Macchine"; negli altri paesi sono conformi alle norme di sicurezza in vigore in quei paesi.



Within the European Union countries our equipments are in accordance with the "Machines" European Directive; in other countries they comply with safety regulations in force in those specific countries.

cima[®]



RIVENDITORE AUTORIZZATO - DEALER

Loc. Molino Quaroni n.7, Montù Beccaria - PV - (ITALY)
Tel. +39.0385.246636 - www.cima.it

