



# cima<sup>®</sup>

ATOMIZZATORI-IMPOLVERATORI

## *Blitz 45 - 50*



**ATOMIZZATORI PNEUMATICI A BASSO VOLUME  
PNEUMATIC LOW VOLUME SPRAYERS**

# Atomizzatori - Sprayers



★ Ampia scelta di testate di distribuzione, tutte dotate del nuovo sistema antigocciolamento (brev. N° 1745689) e di dispositivi di diffusione (mani e/o cannoni) di diverse dimensioni, **orientabili ed intercambiabili** per garantire, su tutte le tipologie di colture, un'eccellente copertura e penetrazione nella vegetazione.



★ Broad range of sprayheads, all equipped with the new anti-drip system (patent Nr. 1745689). Sprayheads' distribution devices (hands or cannons) are available in different sizes, **adjustable and interchangeable** to guarantee a better spray penetration through the canopy and a complete coverage on any type of crop.



★ **Regolatori a disco rotante con 15 fori calibrati** (brev. N° 23238), sostituiscono il sistema a pastiglie. **Erogazione da 70 a 3400 litri/ora**



★ **Rotating calibration discs, 15 positions** (patent Nr. 23238), very easy to adjust: **delivery from 70 to 3400 l/h**

★ **Mozzi delle ruote a carreggiata ed altezza regolabile.**

★ **Wheel-hubs: adjustable in width and height.**

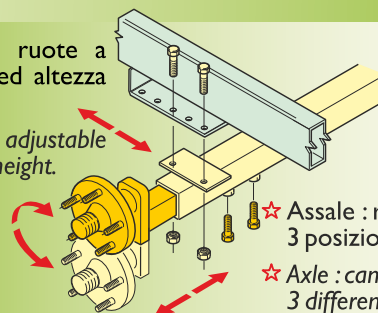

★ **Assale: regolazione su 3 posizioni.**

★ **Axle: can be adjusted to 3 different positions.**

★ **Timone: regolabile in lunghezza ed altezza**

*Drawbar: adjustable in length and height*

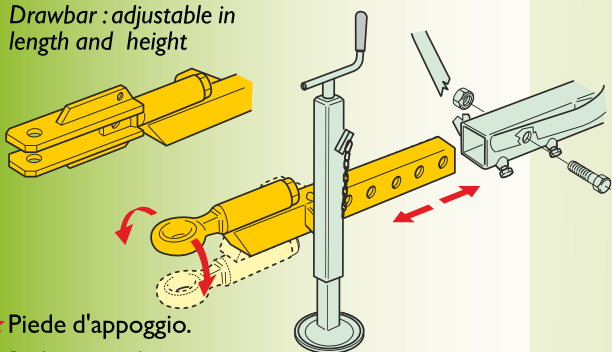

★ **Piede d'appoggio. Parking stand.**



# Blitz 45 - 50

★ Serbatoio in polietilene rotazionale, apertura di riempimento di grandi dimensioni (ø460) con coperchio a cerniera, indicatori di livello. Serbatoio lavamani l.30.

★ Telaio in acciaio, verniciatura elettrostatica con polvere poliestere.

★ Ventola centrifuga chiusa ad alta pressione, in acciaio, con disinnesto; carter in polietilene rotazionale.

★ Idromiscelatore integrato nel filtro a tazza.

★ Doppia agitazione, idraulica e pneumatica.

★ Controllo dal posto operatore dell'erogazione con due elettrovalvole.

★ Il serbatoio lavaimpianto (a richiesta), se mantenuto pieno, conferisce un'ottima stabilità anche a macchina vuota, essendo collocato sotto al serbatoio principale.



★ Polyethylene tank. Large filling opening (ø460) with hinged lid, calibrated level indicators. 30 litres fresh water tank.

★ Steel frame, electrostatic painted with polyester powder.

★ Hydraulic pre-mixer incorporated within the basket filter at the fill opening.

★ Two agitation systems, liquid and air.

★ Steel high pressure radial fan (fan clutch in option), polyethylene fan housing.

★ Two lever operated valves, reachable from tractor seat. (Electro-valve with remote control in option).

★ The (optional) spray-line rinsing tank, when full, gives the sprayer a very good stability even if the sprayer is empty due to its placement below the main tank.



★ Trasmissione a cinghia poly-V che assorbe le sollecitazioni. **Funzionamento per oltre 5000 ore.** Il tenditore automatico evita lo slittamento e quindi l'usura. La qualità della polverizzazione resta inalterata nel tempo.

★ Ruota libera di sicurezza per arresto improvviso.

★ Poly-V belt drive, to absorb all the stresses. **Long life belt - over 5000 hours.** The automatic tensioner keeps belt tension constant, avoiding slipping and wear. High quality atomization after several years of use.

★ Overrunning clutch - Safety stop device in the event the PTO is suddenly stopped.



★ Regolatore di pressione manuale (a comando elettrico dal posto operatore a richiesta).

★ Manometro (ø100) ben visibile dal posto operatore.

★ Filtro di grande portata: **240 l/min.**

★ Pressure regulator with manual controls (optional electro-control from tractor seat).

★ 100mm pressure gauge, easily visible from tractor seat.

★ Large capacity delivery filter : **240 l/min.**



★ La pompa centrifuga di fabbricazione C.I.M.A. (senza membrane e valvole) costruita in materiale anticorrosivo è **esente da manutenzione.** La cinghia di trasmissione 3V è dotata di tenditore automatico.



★ C.I.M.A.'s centrifugal pump (no diaphragms or valves), is made of anticorrosive material and **does not require any maintenance.** The pump is driven by a 3-V belt equipped with an automatic tensioner.



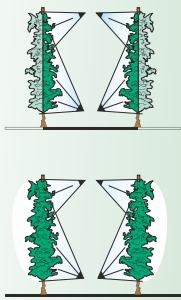

**T.4M**  
Blitz 45 (T.4M.45T)  
Blitz 50 (T.4M.50T)

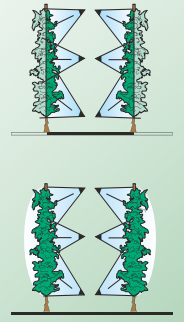
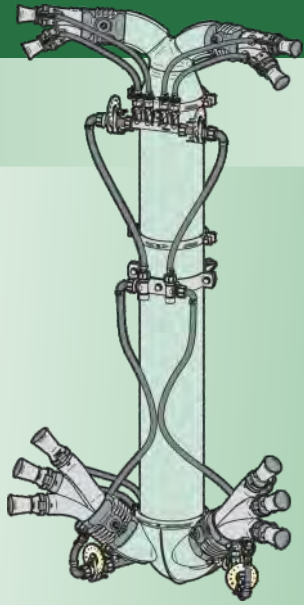

**T.6M**  
Blitz 45 (T.6M2D.45T)  
Blitz 50 (T.6M2D.50T)

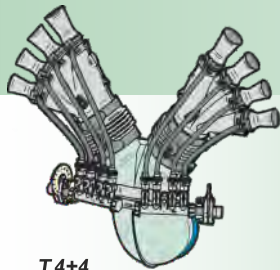
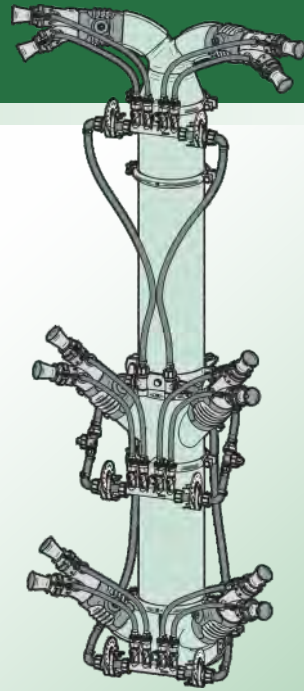

**T.4+4**  
Blitz 45 (T.4+4.45T)  
Blitz 50 (T.4+4.50T)

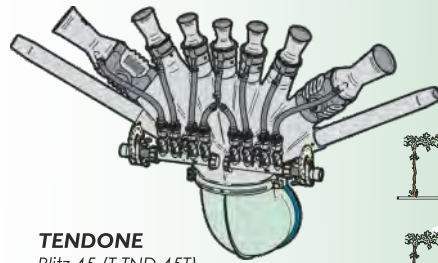
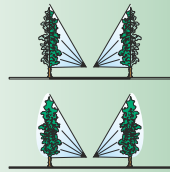

**TENDONE**  
Blitz 45 (T.TND.45T)  
Blitz 50 (T.TND.50T)

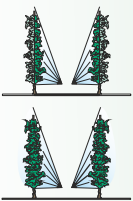
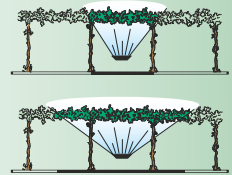

**T.5+5**  
Blitz 45 (T.5+5.45T)  
Blitz 50 (T.5+5.50T)

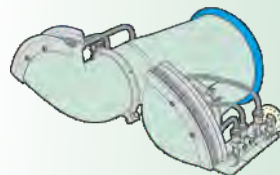
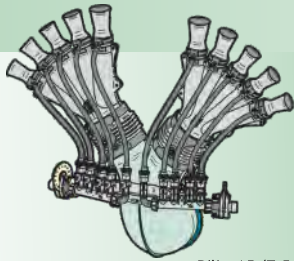

**2 VENTAGLI - 2 FISHTAILS**  
Blitz 45 (T.2V3S.45T)  
Blitz 50 (T.2V4.50T) - (T.2V3L.50T)

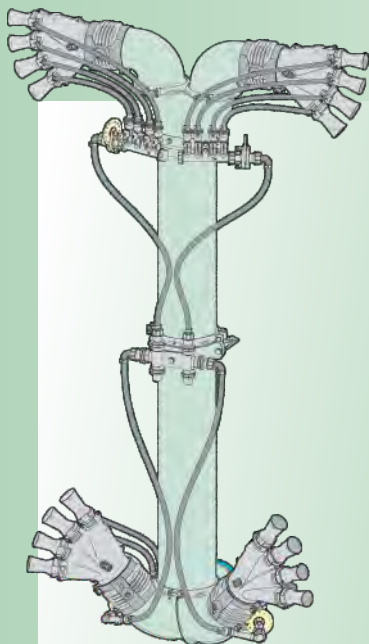
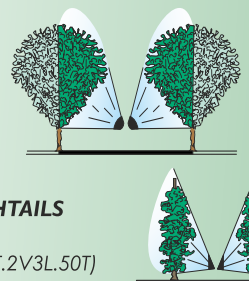

**TC.2M2M**  
Blitz 45 (TC.2M2M.45T)  
Blitz 50 (TC.2M2M.50T)

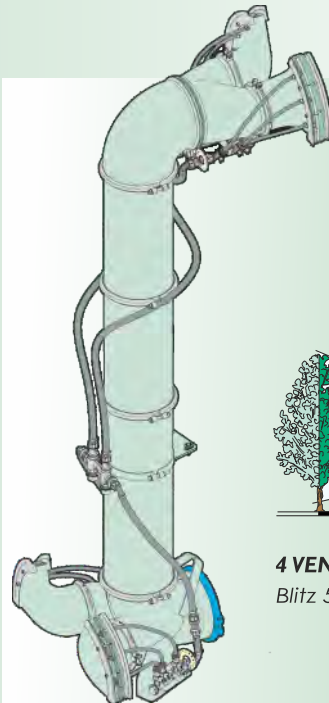
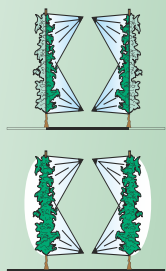

**4 VENTAGLI - 4 FISHTAILS**  
Blitz 50 (T.4V.50T)

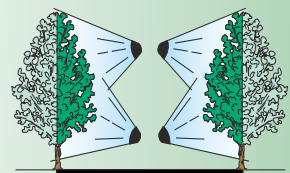

# TESTATE -

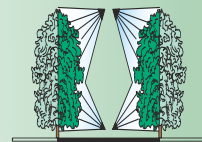
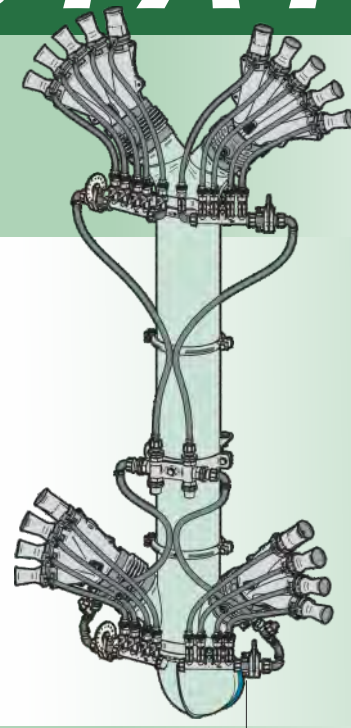
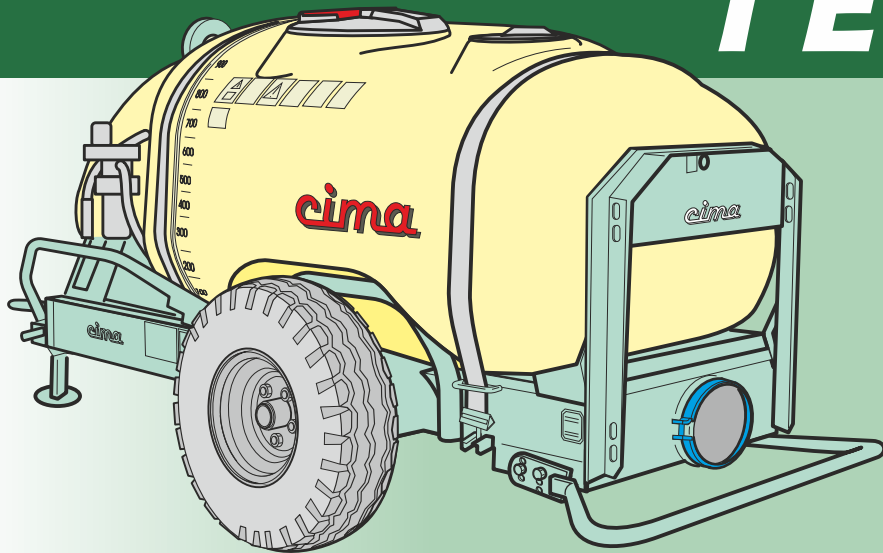

**CAFFÈ - COFFEE**  
Blitz 45 (T.CA.45T)  
Blitz 50 (T.CA.50T)

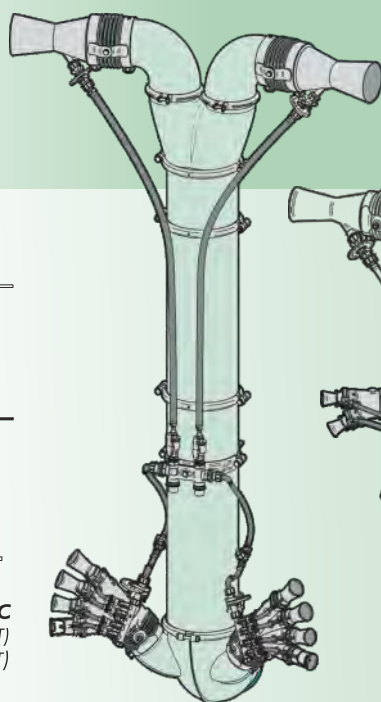

**TC.2M2C**  
Blitz 45 (TC.2M2C.45T)  
Blitz 50 (TC.2M2C.50T)

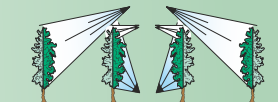
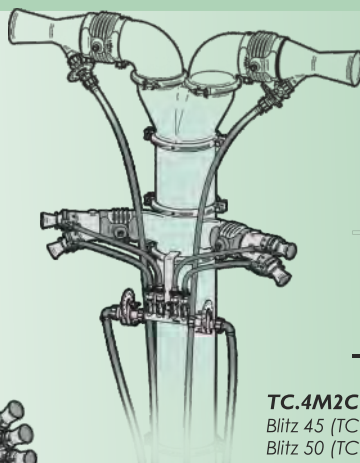

**TC.4M2C**  
Blitz 45 (TC.4M2C.45T)  
Blitz 50 (TC.4M2C.50T)

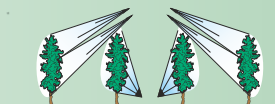
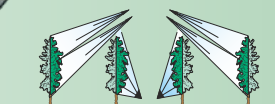
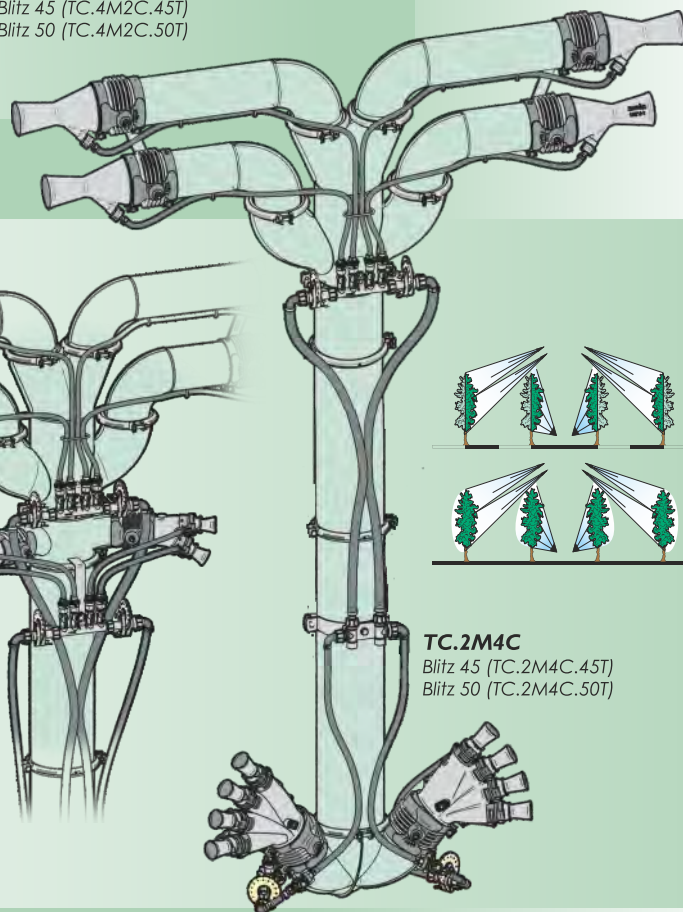

**TC.2M4C**  
Blitz 45 (TC.2M4C.45T)  
Blitz 50 (TC.2M4C.50T)

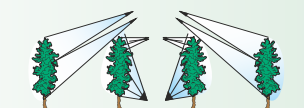
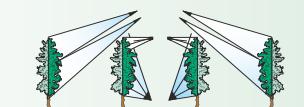

**TC.4M4C**  
Blitz 45 (TC.4M4C.45T)  
Blitz 50 (TC.4M4C.50T)

# SPRAYHEADS

PER ZONE VENTOSE  
FOR WINDY AREAS

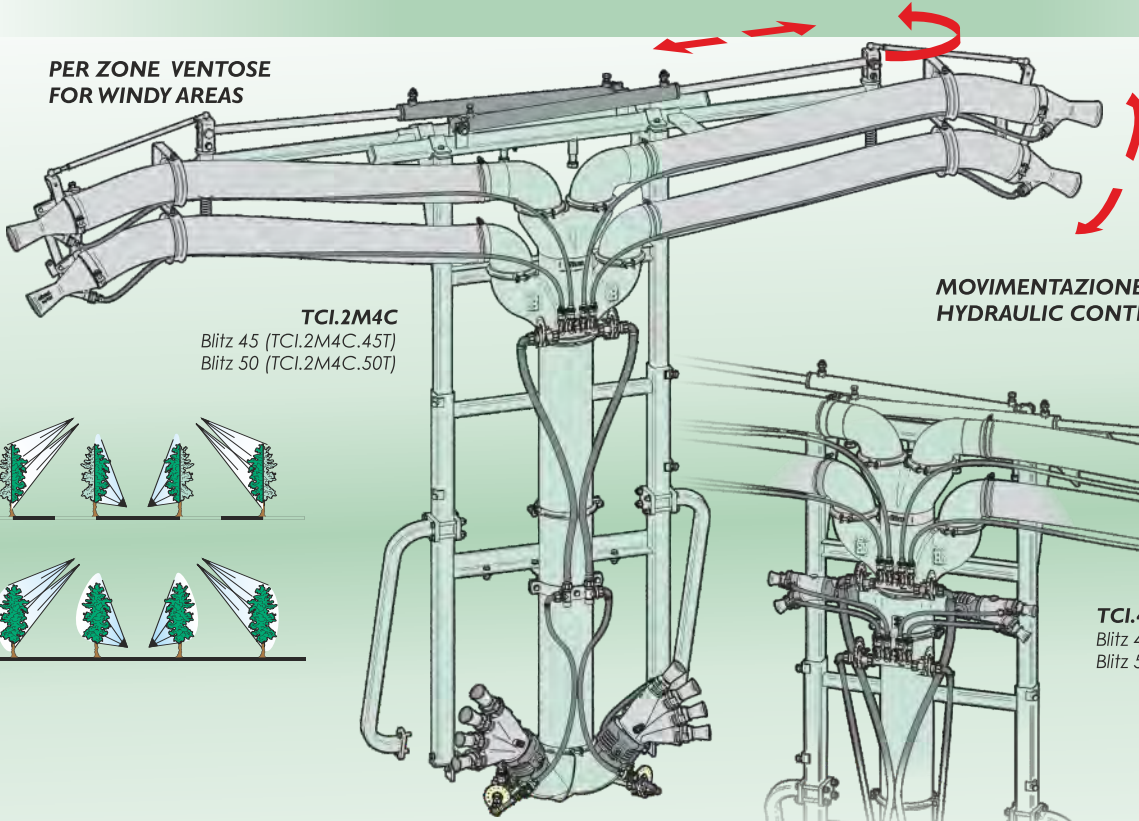

**TCI.2M4C**  
Blitz 45 (TCI.2M4C.45T)  
Blitz 50 (TCI.2M4C.50T)

MOVIMENTAZIONE IDRAULICA  
HYDRAULIC CONTROL

**TCI.4M4C**  
Blitz 45 (TCI.4M4C.45T)  
Blitz 50 (TCI.4M4C.50T)

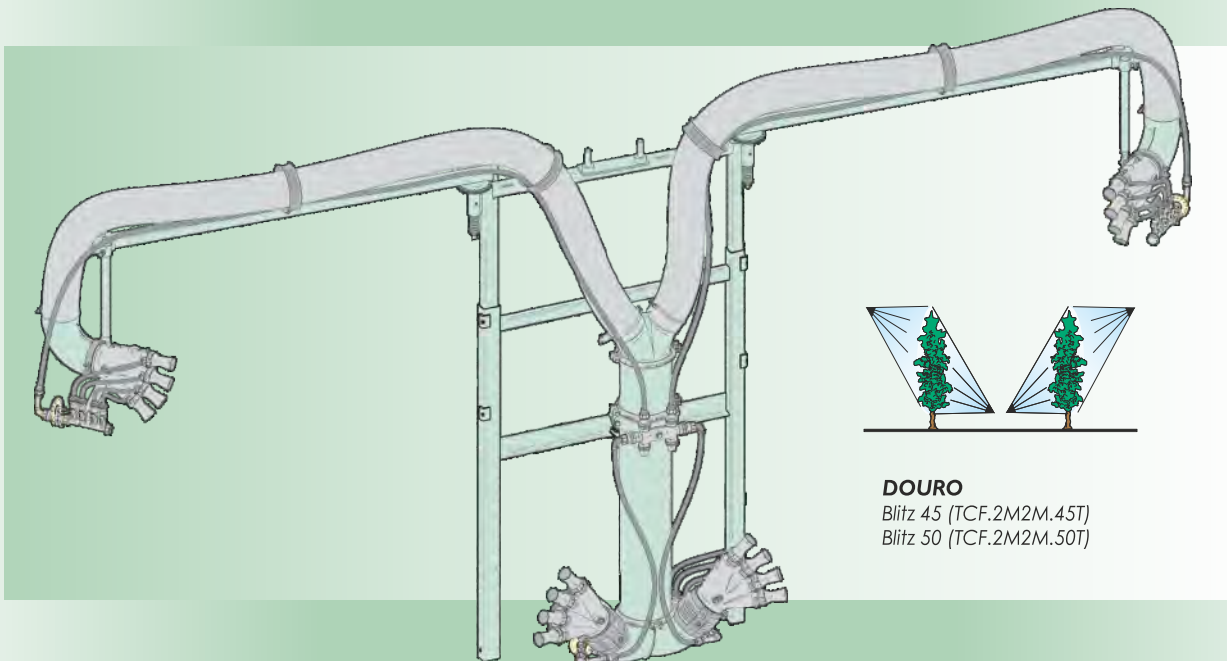

**DOURO**  
Blitz 45 (TCF.2M2M.45T)  
Blitz 50 (TCF.2M2M.50T)

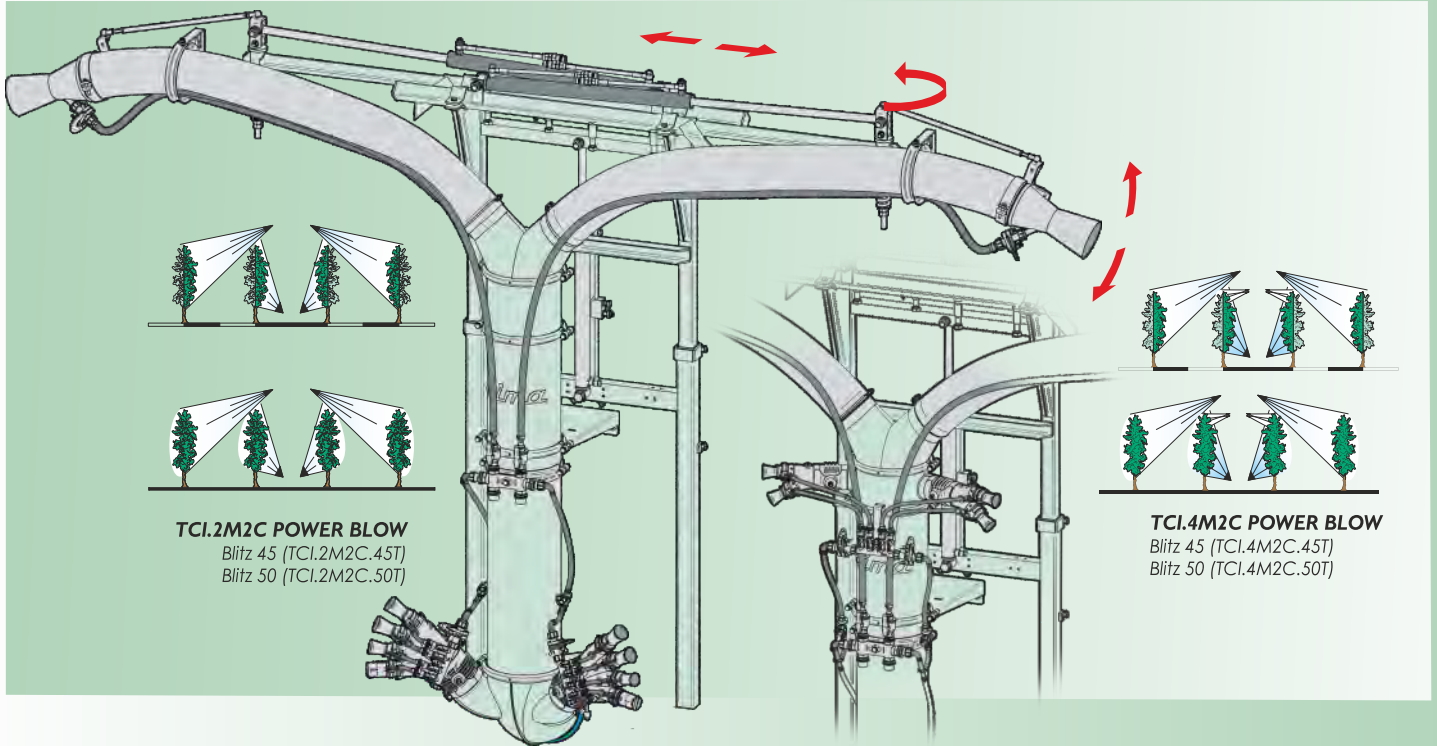

**TCI.2M2C POWER BLOW**  
 Blitz 45 (TCI.2M2C.45T)  
 Blitz 50 (TCI.2M2C.50T)

**TCI.4M2C POWER BLOW**  
 Blitz 45 (TCI.4M2C.45T)  
 Blitz 50 (TCI.4M2C.50T)

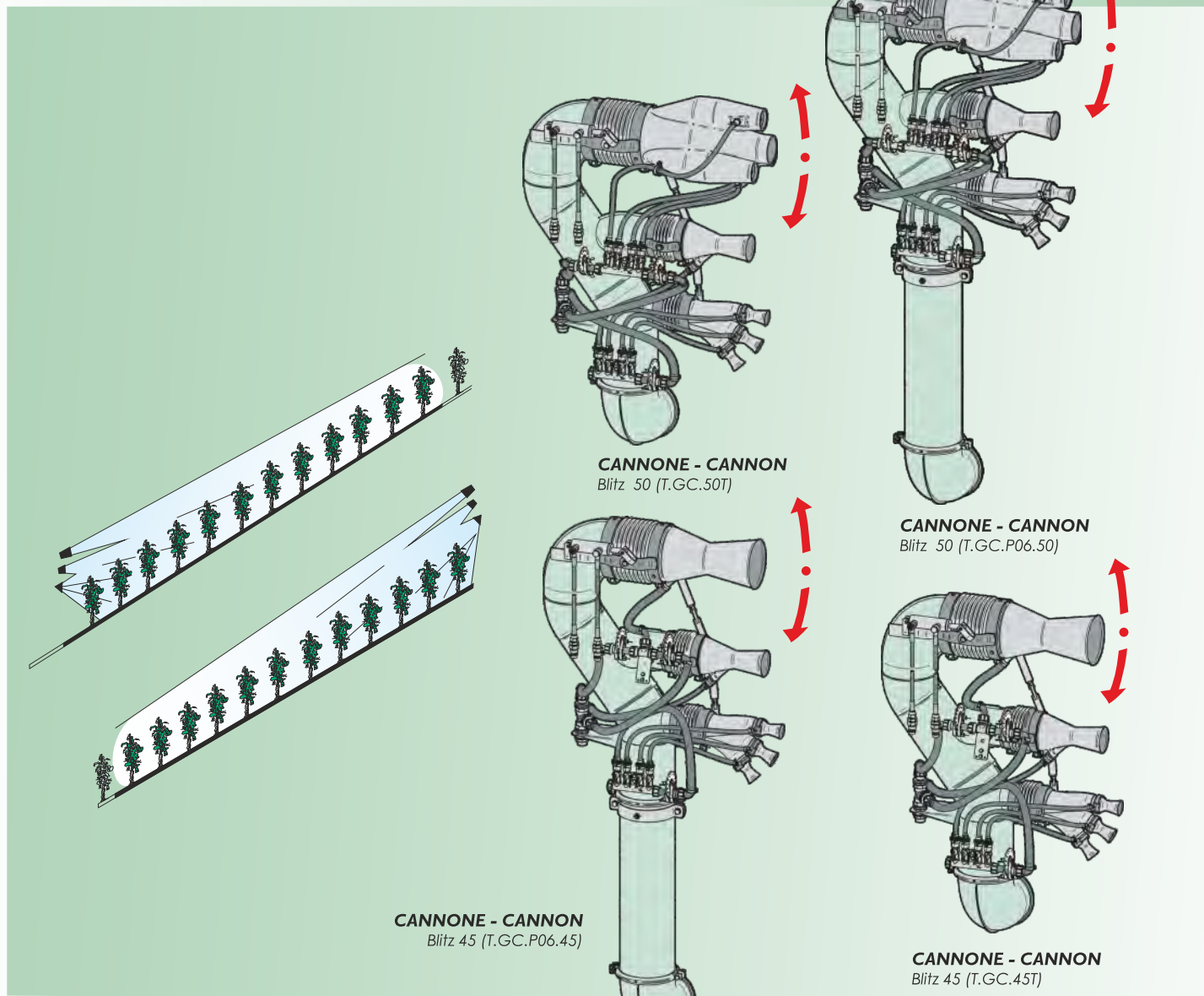

**CANNONE - CANNON**  
 Blitz 50 (T.GC.50T)

**CANNONE - CANNON**  
 Blitz 50 (T.GC.P06.50)

**CANNONE - CANNON**  
 Blitz 45 (T.GC.P06.45)

**CANNONE - CANNON**  
 Blitz 45 (T.GC.45T)

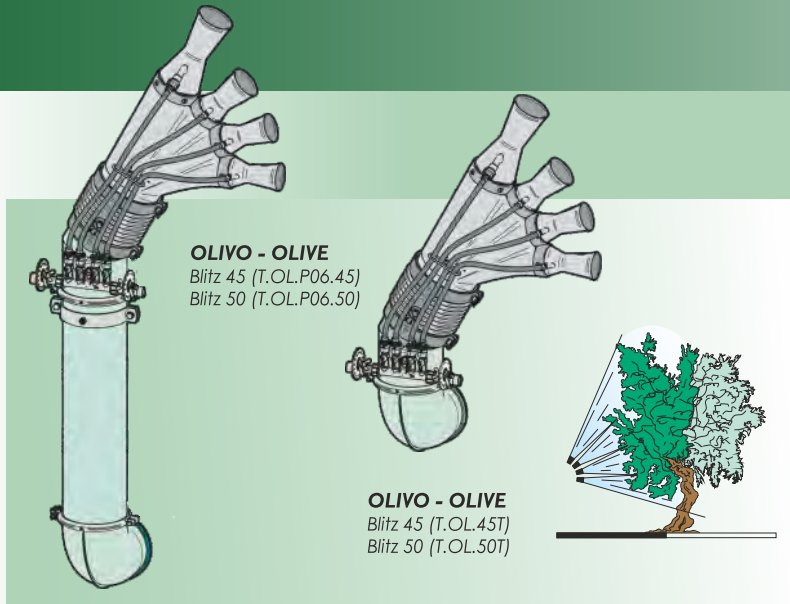

**OLIVO - OLIVE**  
Blitz 45 (T.OL.P06.45)  
Blitz 50 (T.OL.P06.50)

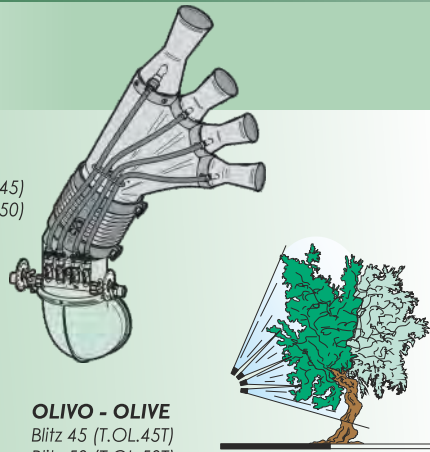

**OLIVO - OLIVE**  
Blitz 45 (T.OL.45T)  
Blitz 50 (T.OL.50T)

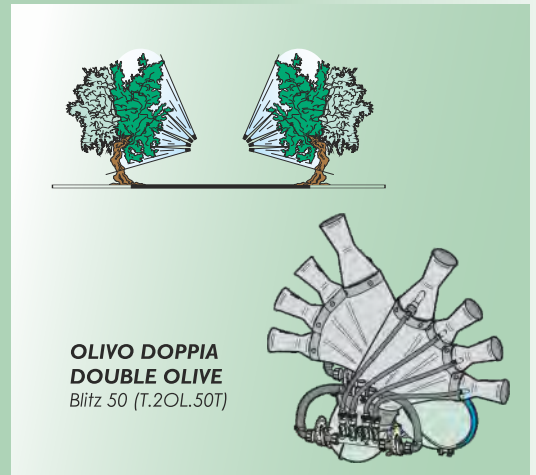

**OLIVO DOPPIA  
DOUBLE OLIVE**  
Blitz 50 (T.2OL.50T)

# ACCESSORI - OPTIONAL DEVICES

**KIT CILINDRI IDRAULICI  
HYDRAULIC-CYLINDER KIT**

disponibile per:  
available for:  
T.4+4  
T.5+5  
T.OL

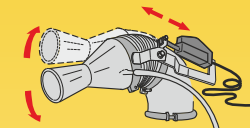
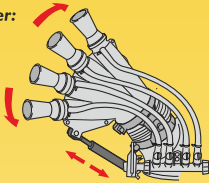

**KIT PISTONI ELETTRICI  
(solo cannoni superiori)  
ELECTRO-CYLINDER KIT  
(only for upper cannons)**

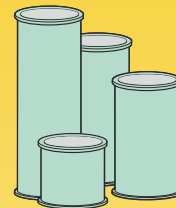

**PROLUNGHE - EXTENSIONS**  
Blitz 45-50 D-175mm  
200mm (X02.186.000) - 400mm (X02.187.000)  
600mm (X02.188.000) - 800mm (X02.189.000)



**COLLARE - COLLAR**  
D-175mm (X05.616.000)

**REGOLATORE ELETTRICO PRESSIONE  
ELECTRICAL PRESSURE REGULATION VALVE**

Blitz 45-50 (D.V.T01)



**LAVABARATTOLI  
CONTAINER  
WASHING DEVICE**  
Blitz 45-50 (KIT.LAV.BOX)



**TIMONE STERZANTE  
STEERING DRAWBAR**

Blitz 45-50 (DIFF.TIM.STRZ.02)  
(DIFF.TIM.STRZ.06)

**GRUPPO 2 ELETTROVALVOLE SUPPLEMENTARI  
2 ADDITIONAL ELECTROVALVES ASSEMBLY**

Blitz 45-50 (D.4E.T11)

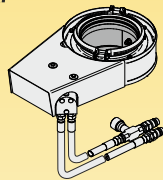

**GIREVOLE IDRAULICO  
HYDRAULIC SWIVELLING DEVICE**  
Blitz 45-50 (T.GIR.I.175T)

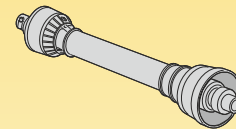

**CARDANO  
CARDAN SHAFT**  
Blitz 45 (KHP.050.110)  
Blitz 50 (KHP.060.110)

**CARDANO OMOCINETICO  
CONSTANT VELOCITY CARDAN SHAFT**

Blitz 45 (KHP.040.120G)  
Blitz 50 (KHP.060.130G)

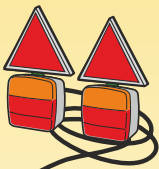
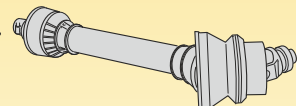

**KIT LUCI POSTERIORI  
REAR LIGHT KIT**  
Blitz 45-50 (KIT.LP.10.03)



**SENSORI ULTRASUONI  
ULTRASONIC SENSOR**  
Blitz 45-50 (D.SU2.EPA.T01)

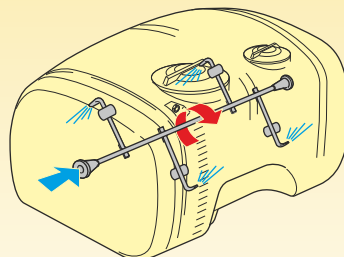

**IDROMISCELATORE ROTANTE A PALE  
ROTARY BLADE HYDRO-MIXER**  
Blitz 50 lt. 1000 - 1500

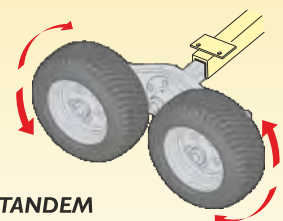

**ASSALI TANDEM  
TANDEM AXLES**

Blitz 45-50 lt. 600-800-1000 STRETTO (DIFF.RT.T.07)  
Blitz 50 lt. 1000 (DIFF.RT.T.02)  
Blitz 50 lt. 1500 (DIFF.RT.T.06)

**E.P.A.**  
Erogazione Proporzionale Avanzamento  
Delivery Proportional to the Advance  
Blitz 45-50 (EPA.T11)

**KIT EASY FARM  
EASY FARM KIT**



Blitz 45-50 (K.EASYFARM.01)





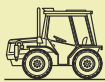

Alcuni accessori sono forniti di serie in certi paesi - Some options are standard supplied in some countries

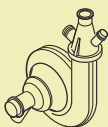

# INFORMAZIONI TECNICHE TECHNICAL INFORMATION

		Blitz 45	Blitz 50
	TRATTRICE	potenza richiesta 33 kW - 45 CV	potenza richiesta 48 kW - 65 CV
	TRACTOR	required power 33 kW - 45 HP	required power 48 kW - 65 HP
	ATOMIZZATORE	potenza assorbita 17 kW - 23 CV	potenza assorbita 24 kW - 33 CV
	SPRAYER	absorbed power 17 kW - 23 HP	absorbed power 24 kW - 33 HP
	VENTOLA	radiale in acciaio chiusa D.450 mm 4500 giri/min. - portata aria: 5400 m <sup>3</sup> /h velocità aria: 188 m/s	radiale in acciaio chiusa D.500 mm 4000 giri/min. - portata aria: 7550 m <sup>3</sup> /h velocità aria: 175 m/s
	FAN	450 mm dia. steel closed radial fan 4500 rpm - air delivery: 5400 m <sup>3</sup> /h air speed: 188 m/s	500 mm dia. steel closed radial fan 4000 rpm - air delivery: 7550 m <sup>3</sup> /h air speed: 175 m/s
	POMPA	centrifuga di alimentazione e agitazione CIMA CD 32 - 4250 giri/min. portata massima 140 l/min. - pressione massima 4,5 kg/cm <sup>2</sup>	
	PUMP	centrifugal spray and agitation CIMA CD 32 pump - 4250 rpm 140 l/min. max delivery - 4,5 kg/cm <sup>2</sup> max pressure	

Valori suscettibili di variazioni in funzione del dispositivo di distribuzione utilizzato  
Values can vary according to the used distribution sprayhead.

		Blitz 45				Blitz 50			
		I. 600	I. 800	I. 1000	I. 1000 stretto - narrow	I. 800	I. 1000	I. 1000 stretto - narrow	I. 1500
	LUNGHEZZA LENGTH	299-343 cm	327-371 cm	321-361 cm	327-371 cm	337-381 cm	332-382 cm	337-381 cm	396-446 cm
	LARGHEZZA WIDTH	109-135 cm	109-135 cm	139-181 cm	113-139 cm	109-135 cm	139-181 cm	113-139 cm	167-209 cm
	ALTEZZA HEIGHT	133-145 cm	140-152 cm	141-153 cm	154-166 cm	140-152cm	141-153 cm	154-166 cm	150-162 cm
	PESO WEIGHT	375 kg	386 kg	434 kg	409 kg	456 kg	502 kg	481 kg	612 kg
	RUOTE TYRES	7.00-12	7.00-12 10/80-12 (opt.)	10/80-12	10/80-12	7.00-12 10/80-12 (opt.)	10/80-12 10,0/75-15 (opt.)	10/80-12 10,0/75-15 (opt.)	10,0/75-15

Le dimensioni e pesi sono a titolo indicativo e possono variare secondo la configurazione della macchina  
The dimensions and weights are given as a guide only and may vary depending on the configuration of the machine

Nei paesi dell'Unione Europea le nostre attrezzature sono conformi alla Direttiva Europea "Macchine"; negli altri paesi sono conformi alle norme di sicurezza in vigore in quei paesi.



Within the European Union countries our equipments are in accordance with the "Machines" European Directive; in other countries they comply with safety regulations in force in those specific countries.

**cima**<sup>®</sup>

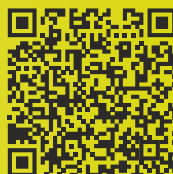

RIVENDITORE AUTORIZZATO - DEALER

Loc. Molino Quaroni n.7, Montù Beccaria - PV - (ITALY)  
Tel. +39.0385.246636 - www.cima.it

