

cima[®]

ATOMIZZATORI-IMPOLVERATORI

Blitz 45 - 50



**ATOMIZZATORI PNEUMATICI A BASSO VOLUME
ATOMIZADOR BAJO VOLUMEN NEUMÁTICO**

Atomizzatori - Atomizadores



☆ Ampia scelta di testate di distribuzione, tutte dotate del nuovo sistema antigocciolamento (brev. N° 1745689) e di dispositivi di diffusione (mani e/o cannoni) di diverse dimensioni, **orientabili ed intercambiabili** per garantire, su tutte le tipologie di colture, un'eccellente copertura e penetrazione nella vegetazione.



☆ Amplia gama de cabezales de distribución, todos equipados con el nuevo sistema antigoteo (pat. N.º 1745689) y dispositivos de difusión (manos y/o cañones) de diferentes dimensiones, **orientables e intercambiables**, para garantizar una excelente cobertura y penetración en cualquier tipo de cultivo.



☆ **Regolatori a disco rotante** con 15 fori calibrati (brev. N° 23238), sostituiscono il sistema a pastiglie. **Erogazione da 70 a 3400 litri/ora**



☆ **Reguladores de disco giratorio** con 15 orificios calibrados (pat. N.º 23238) sustituyen el sistema de pastillas. **Distribución de 70 a 3400 l/h**

☆ **Mozzi delle ruote a carreggiata ed altezza regolabile.**

☆ **Cubos de las ruedas de distancia y altura regulables.**

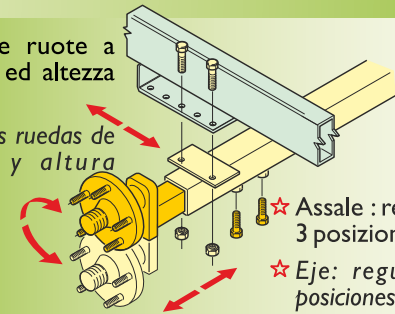

☆ **Assale : regolazione su 3 posizioni.**

☆ **Eje: regulable en 3 posiciones.**

☆ **Timone : regolabile in lunghezza ed altezza**

☆ **Barra de remolque de longitud y altura regulable**

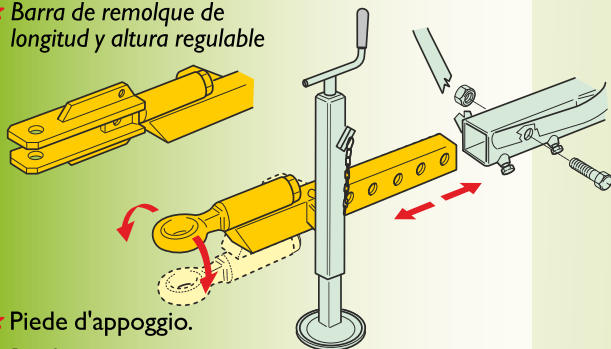

☆ **Piede d'appoggio.**

☆ **Pie de apoyo.**



Blitz 45 - 50

★ Serbatoio in polietilene rotazionale, apertura di riempimento di grandi dimensioni (ø460) con coperchio a cerniera, indicatori di livello. Serbatoio lavamani I.30.

★ Telaio in acciaio, verniciatura elettrostatica con polvere poliestere.

★ Ventola centrifuga chiusa ad alta pressione, in acciaio, con disinnesto; carter in polietilene rotazionale.

★ **Idromiscelatore integrato nel filtro a tazza.**

★ **Doppia agitazione, idraulica e pneumatica.**

★ Controllo dal posto operatore dell'erogazione con due elettrovalvole.

★ Il serbatoio lavaimpianto (a richiesta), se mantenuto pieno, conferisce un'ottima stabilità anche a macchina vuota, essendo collocato sotto al serbatoio principale.



★ Tanque rotomoldeado de polietileno; apertura de llenado de grandes dimensiones (ø460) con tapa engoznada e indicadores de nivel. Tanque para el lavado de las manos I.30.

★ Bastidor de acero; pintura electrostática con polvo poliéster.

★ **Hidromezcladora integrada en el filtro de taza.**

★ **Doble agitación, hidráulica y neumática.**

★ Ventilador centrifugo cerrado de alta presión de acero, con desacoplamiento; cárter rotomoldeado de polietileno.

★ Control de la distribución desde el puesto de operador, con dos electroválvulas.

★ Si se mantiene lleno, el tanque para el lavado de la instalación (opcional) garantiza una óptima estabilidad incluso con la máquina vacía, ya que está situado debajo del tanque principal.



★ Regulatore di pressione manuale (a comando elettrico dal posto operatore a richiesta).

★ Manometro (ø100) ben visibile dal posto operatore.

★ Filtro di grande portata: **240 l/min.**

★ *Regulador de presión manual (mando eléctrico desde el puesto del operador opcional).*

★ *Manómetro (ø100) bien visible desde el puesto del operador.*

★ *Filtro de gran caudal: **240 l/min.***

★

★

★ **Transmisión con correa poly-V, que absorbe los esfuerzos. Funcionamiento por más de 5000 horas.**

El tensor automático evita el deslizamiento y, en consecuencia, el desgaste.

La calidad de la pulverización permanece inalterada en el tiempo.

★ **Rueda libre de seguridad para paradas repentinas.**



★ **La pompa centrifuga di fabbricazione C.I.M.A. (senza membrane e valvole) costruita in materiale anticorrosivo è esente da manutenzione.** La cinghia di trasmissione 3V è dotata di tenditore automatico.



★ **La bomba centrifuga CIMA (sin membranas ni válvulas), de material anticorrosivo, es libre de mantenimiento.** La correa de transmisión 3V está dotada de tensor automático.



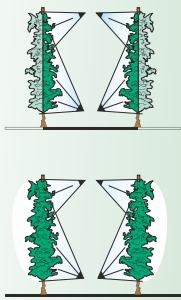

T.4M
Blitz 45 (T.4M.45T)
Blitz 50 (T.4M.50T)

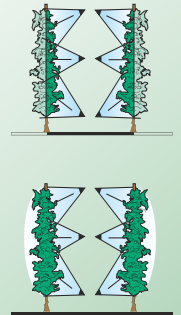
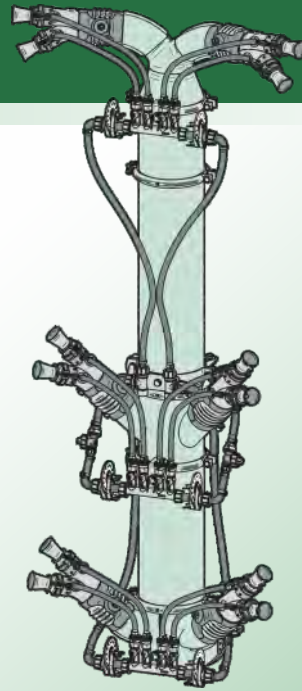
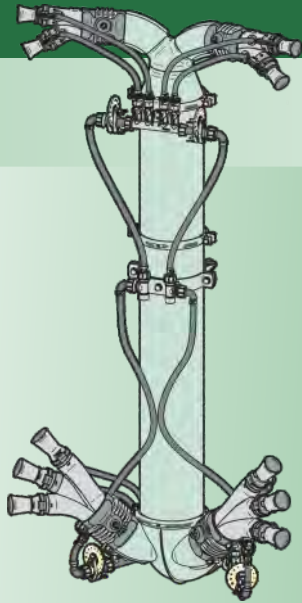

T.6M
Blitz 45 (T.6M2D.45T)
Blitz 50 (T.6M2D.50T)

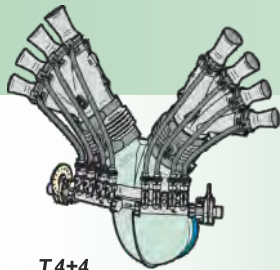

T.4+4
Blitz 45 (T.4+4.45T)
Blitz 50 (T.4+4.50T)

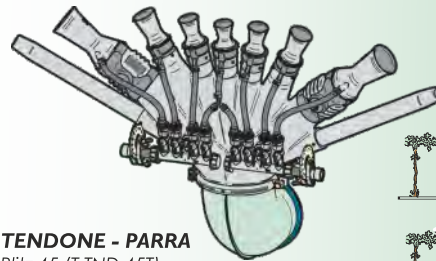
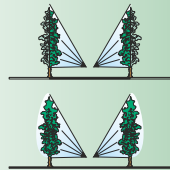

TENDONE - PARRA
Blitz 45 (T.TND.45T)
Blitz 50 (T.TND.50T)

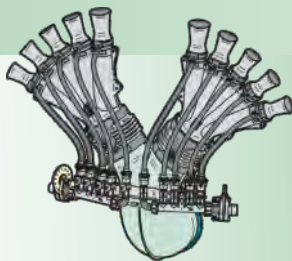
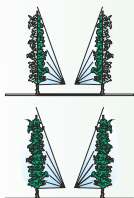
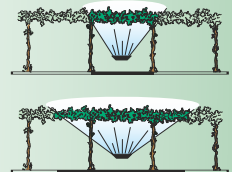

T.5+5
Blitz 45 (T.5+5.45T)
Blitz 50 (T.5+5.50T)

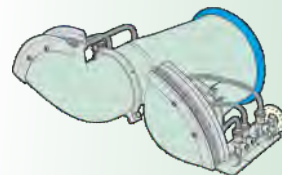

2 VENTAGLI - 2 ABANICOS
Blitz 45 (T.2V3S.45T)
Blitz 50 (T.2V4.50T) - (T.2V3L.50T)

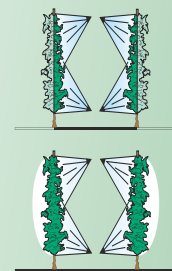
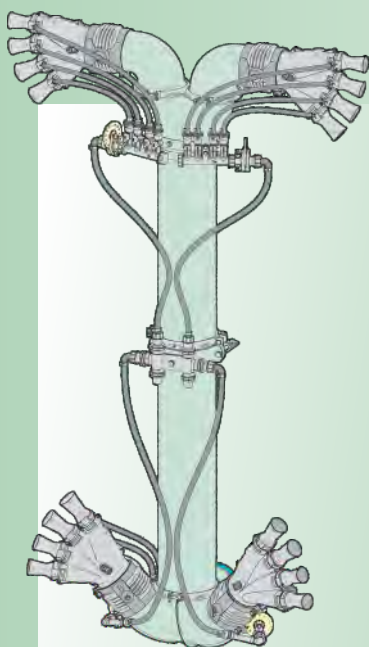
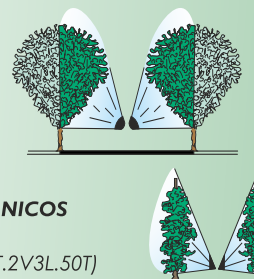

TC.2M2M
Blitz 45 (TC.2M2M.45T)
Blitz 50 (TC.2M2M.50T)

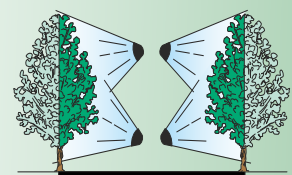

4 VENTAGLI - 4 ABANICOS
Blitz 50 (T.4V.50T)

TESTATE -

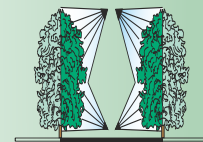
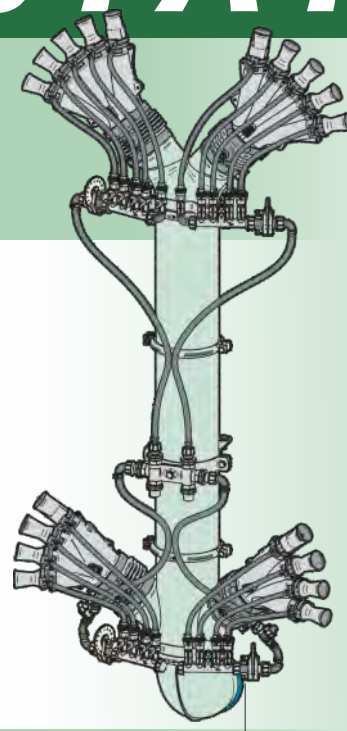
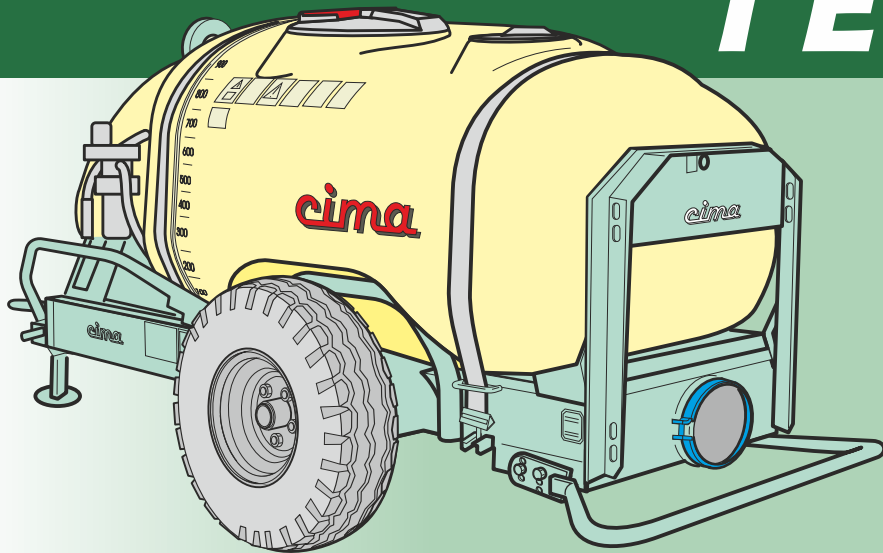

CAFFÈ - CAFÉ
Blitz 45 (T.CA.45T)
Blitz 50 (T.CA.50T)

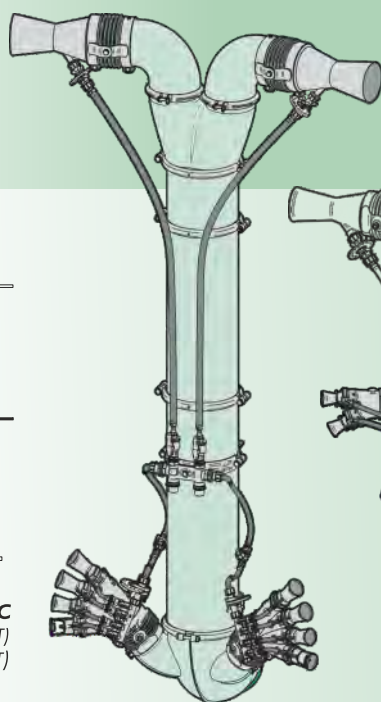

TC.2M2C
Blitz 45 (TC.2M2C.45T)
Blitz 50 (TC.2M2C.50T)

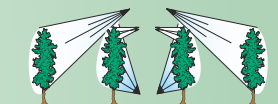
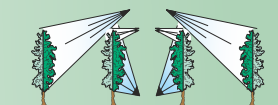
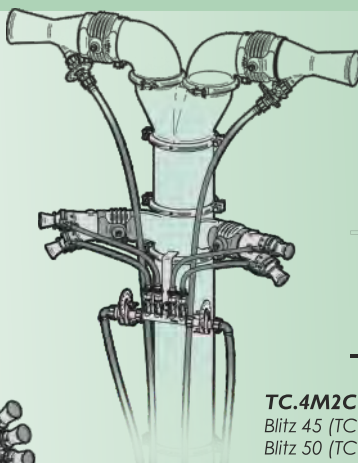

TC.4M2C
Blitz 45 (TC.4M2C.45T)
Blitz 50 (TC.4M2C.50T)

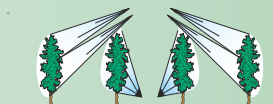
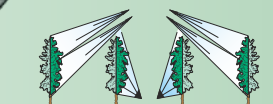
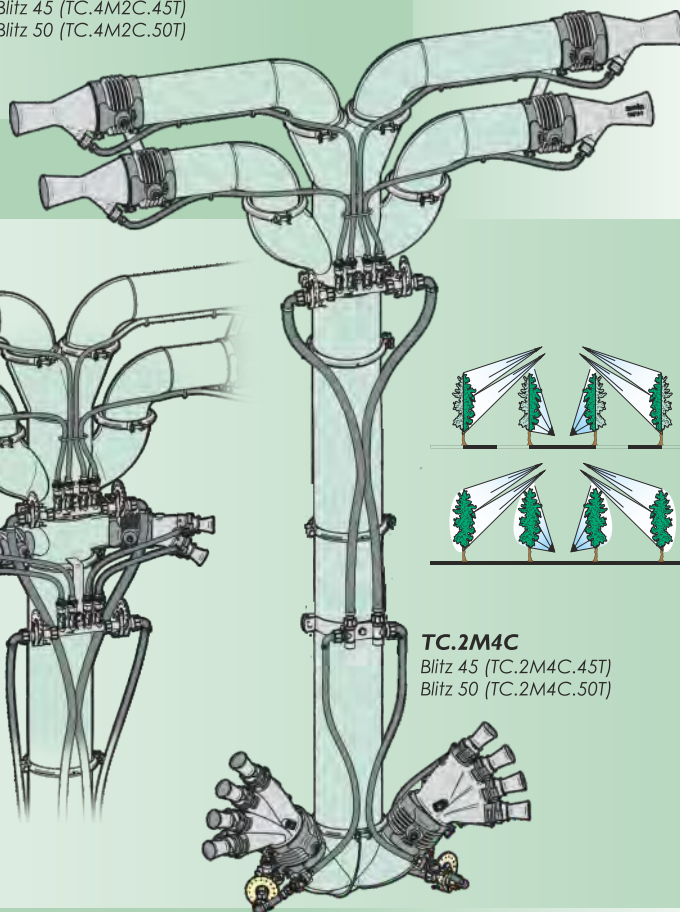

TC.2M4C
Blitz 45 (TC.2M4C.45T)
Blitz 50 (TC.2M4C.50T)

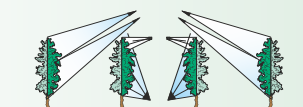

TC.4M4C
Blitz 45 (TC.4M4C.45T)
Blitz 50 (TC.4M4C.50T)

CABEZALES

PER ZONE VENTOSE
EN ZONAS VENTOSAS

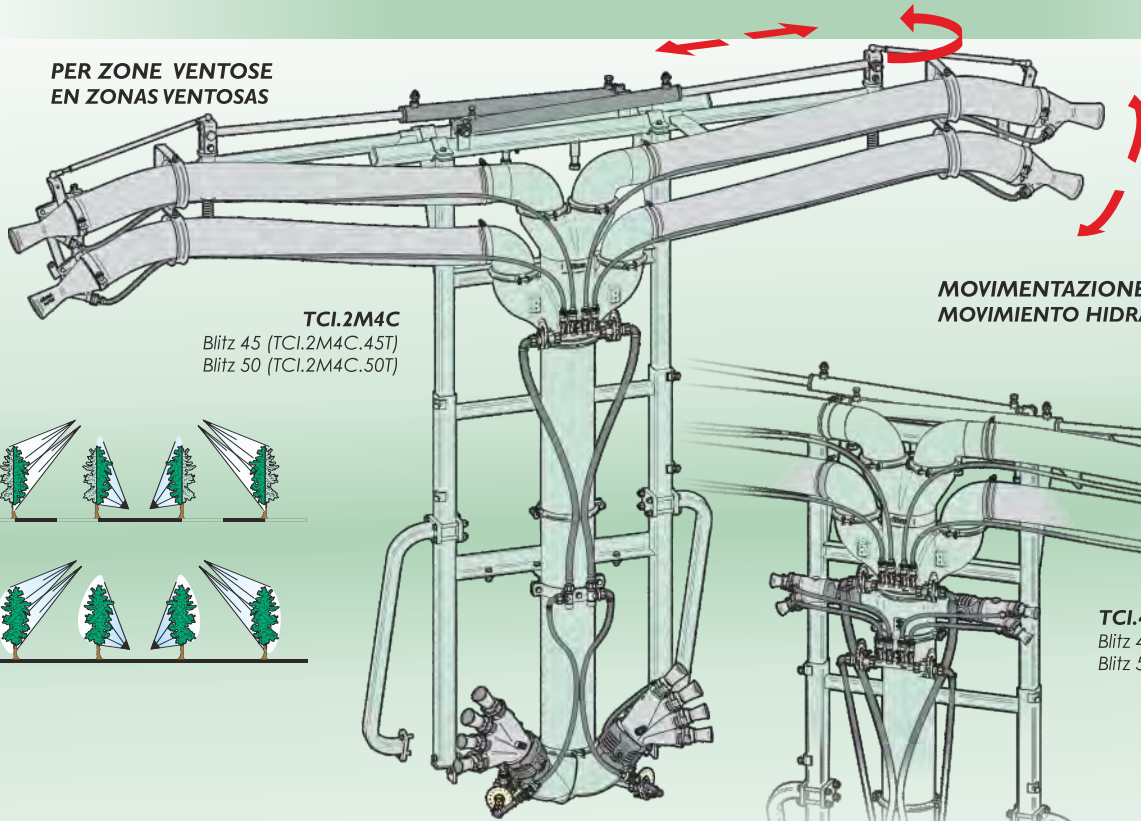

TCI.2M4C

Blitz 45 (TCI.2M4C.45T)
Blitz 50 (TCI.2M4C.50T)

MOVIMENTAZIONE IDRAULICA
MOVIMIENTO HIDRÁULICO

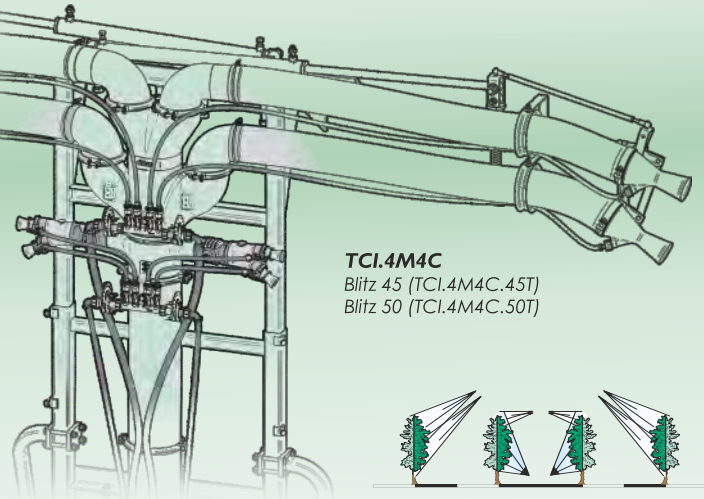

TCI.4M4C

Blitz 45 (TCI.4M4C.45T)
Blitz 50 (TCI.4M4C.50T)

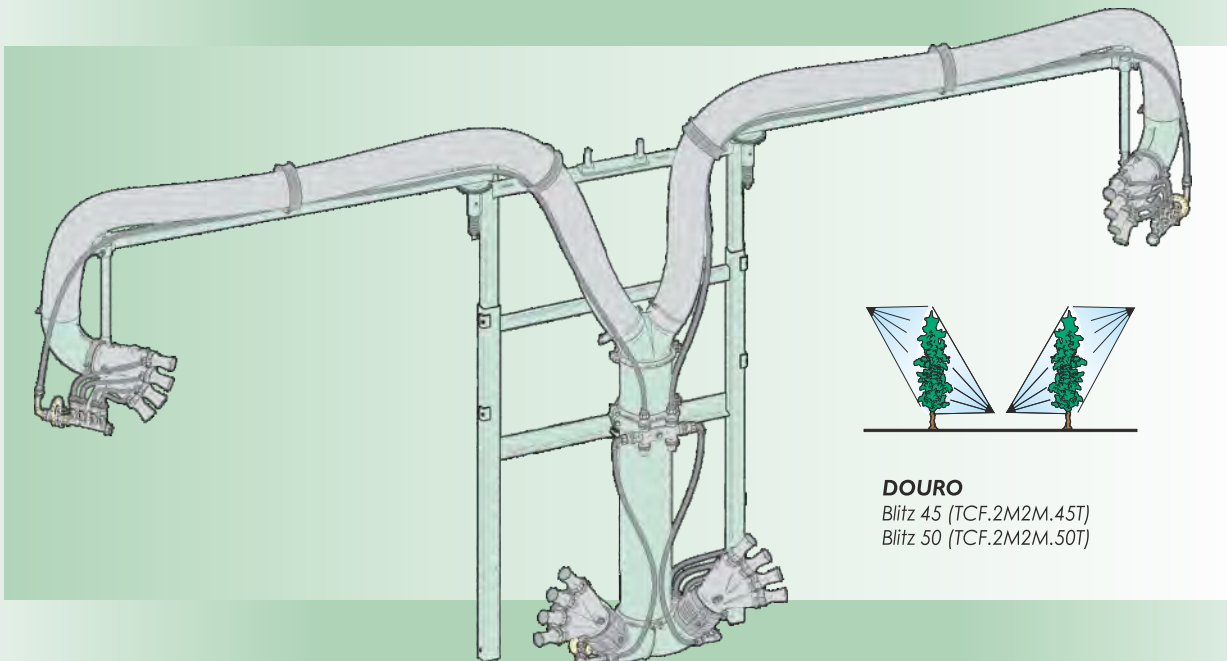

DOURO

Blitz 45 (TCF.2M2M.45T)
Blitz 50 (TCF.2M2M.50T)

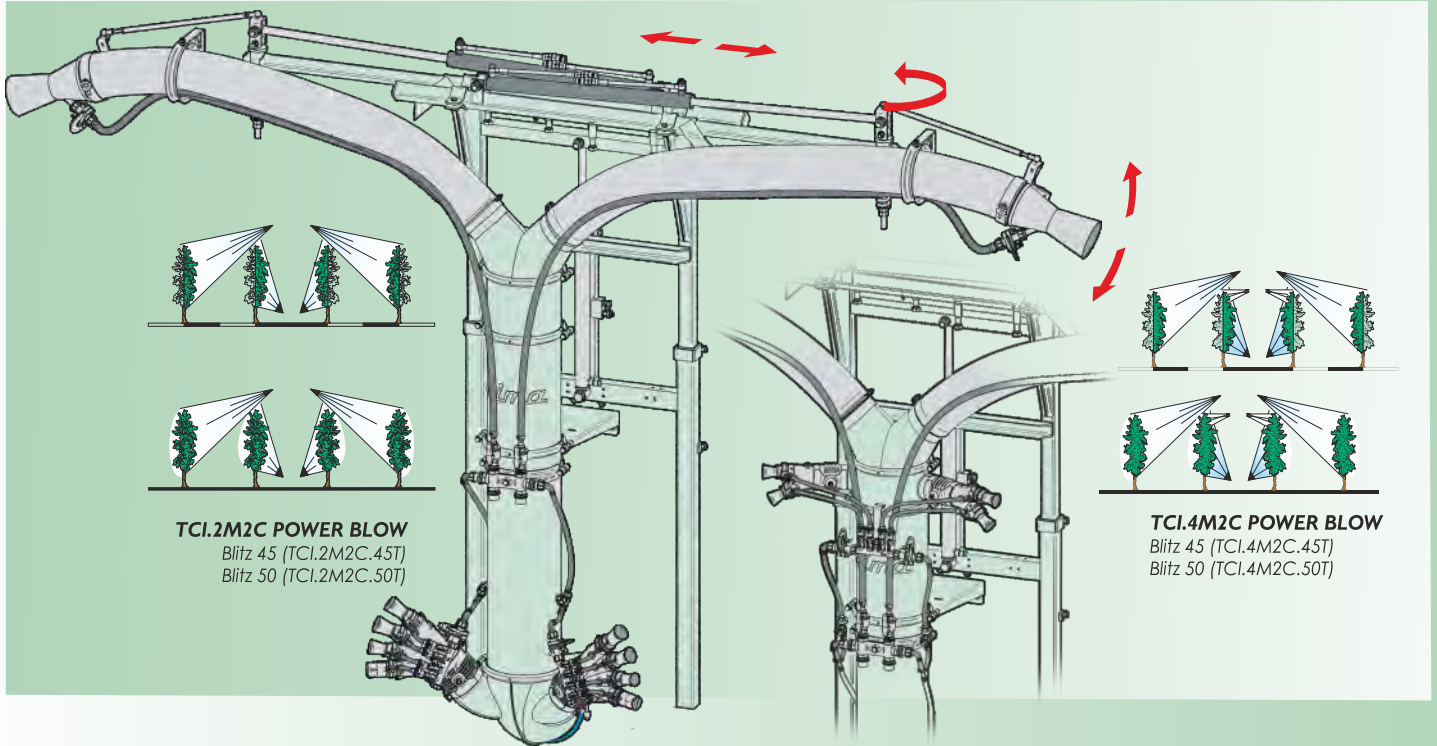

TCI.2M2C POWER BLOW
 Blitz 45 (TCI.2M2C.45T)
 Blitz 50 (TCI.2M2C.50T)

TCI.4M2C POWER BLOW
 Blitz 45 (TCI.4M2C.45T)
 Blitz 50 (TCI.4M2C.50T)

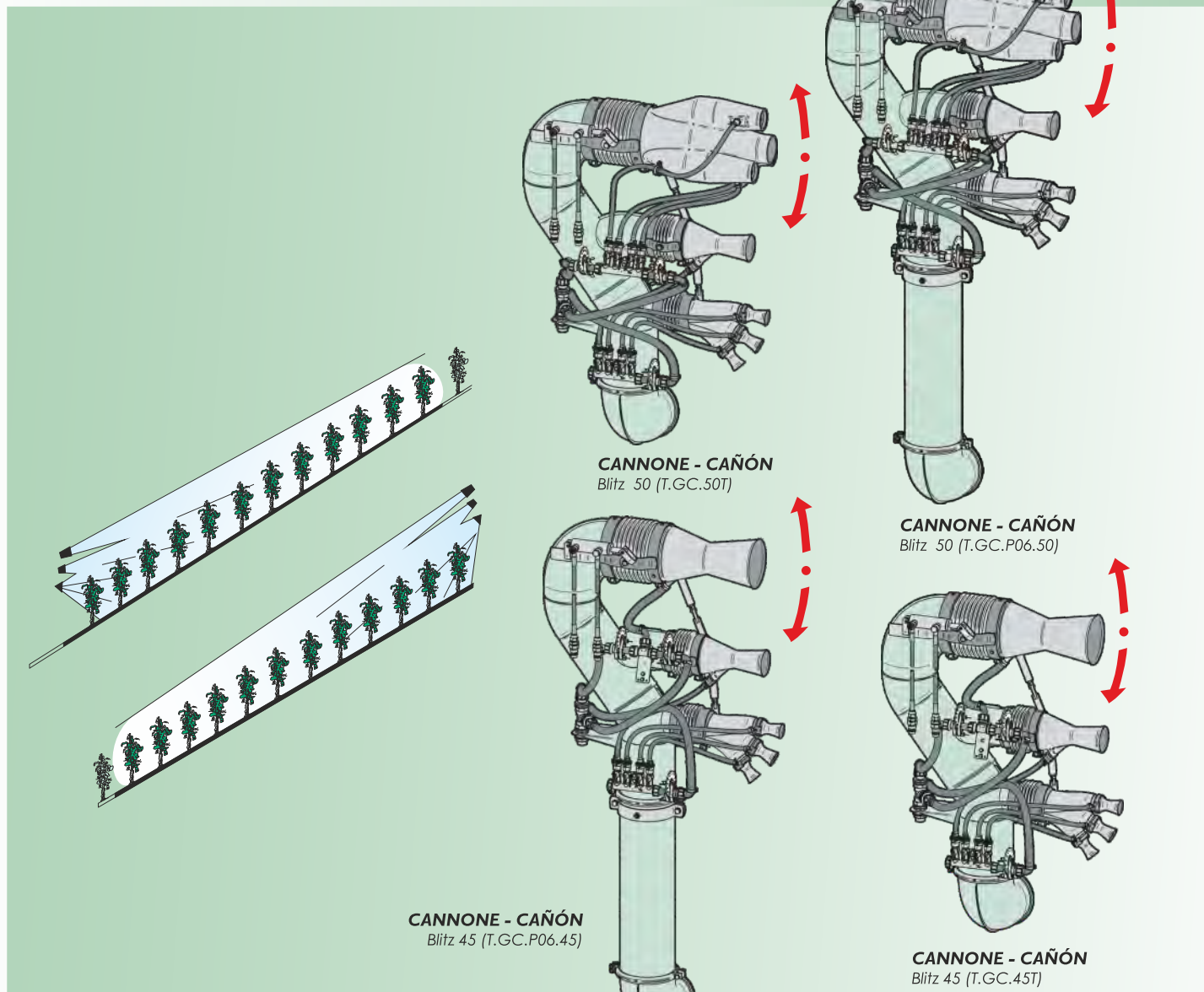

CANNONE - CAÑÓN
 Blitz 50 (T.GC.50T)

CANNONE - CAÑÓN
 Blitz 50 (T.GC.P06.50)

CANNONE - CAÑÓN
 Blitz 45 (T.GC.P06.45)

CANNONE - CAÑÓN
 Blitz 45 (T.GC.45T)

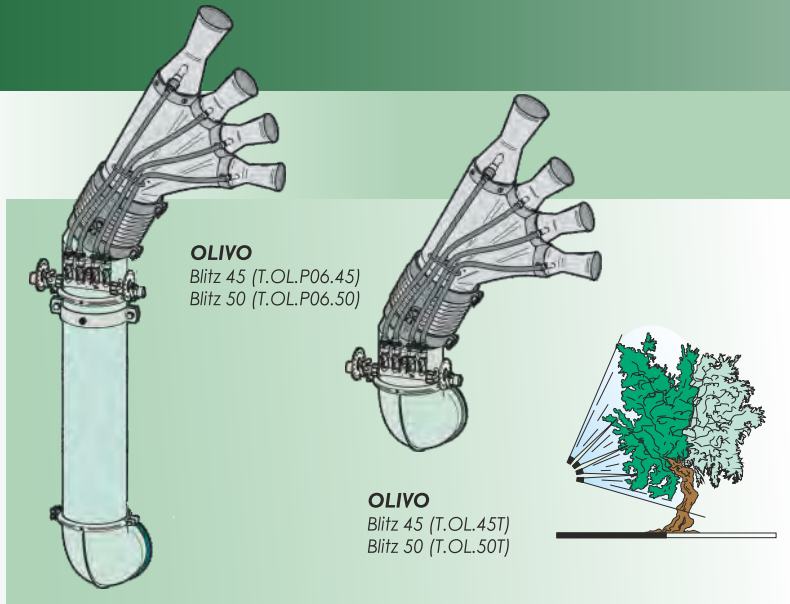

OLIVO
Blitz 45 (T.OL.P06.45)
Blitz 50 (T.OL.P06.50)

OLIVO
Blitz 45 (T.OL.45T)
Blitz 50 (T.OL.50T)

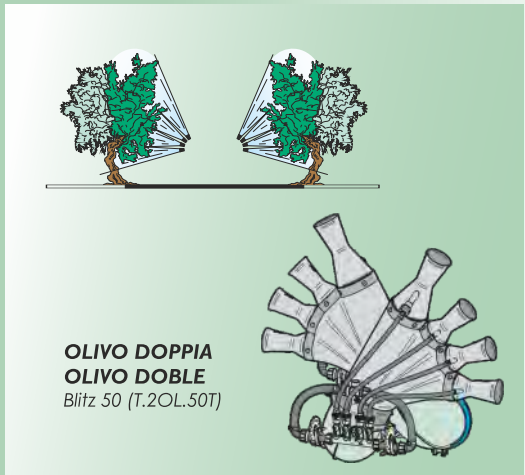

**OLIVO DOPPIA
OLIVO DOBLE**
Blitz 50 (T.2OL.50T)

ACCESSORI - ACCESORIOS DISPONIBILI

**KIT CILINDRI IDRAULICI
KIT DE PISTONES HIDRÁULICOS**

disponibile per:
disponible para:
T.4+4
T.5+5
T.OL

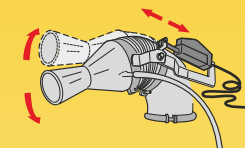
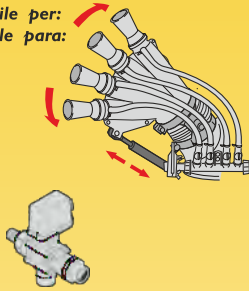

KIT PISTONI ELETTRICI
(solo cannoni superiori)
KIT DE PISTONES ELÉCTRICOS
(solo para cañones superiores)

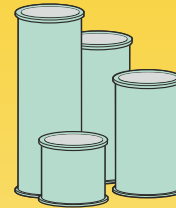

PROLUNGHE - ALGADERAS
Blitz 45-50 D-175mm
200mm (X02.186.000) - 400mm (X02.187.000)
600mm (X02.188.000) - 800mm (X02.189.000)



COLLARE - COLLARES
D-175mm (X05.616.000)

**REGOLATORE ELETTRICO PRESSIONE
REGULADOR ELÉCTRICO DE PRESIÓN**

Blitz 45-50 (D.V.T01)

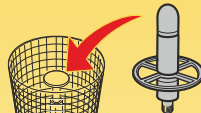

**LAVABARRATI
DISPOSITIVO DE LAVADO
DE CONTENEDORES**
Blitz 45-50 (KIT.LAV.BOX)

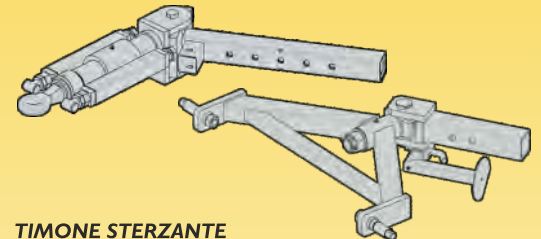

**TIMONE STERZANTE
BARRAS DE REMOLQUE CON DIRECCIÓN**
Blitz 45-50 (DIFF.TIM.STRZ.02) (DIFF.TIM.STRZ.06)

**GRUPPO 2 ELETTROVALVOLE SUPPLEMENTARI
GRUPO 2 ELECTROVÁLVULAS ADICIONALES**

Blitz 45-50 (D.4E.T11)

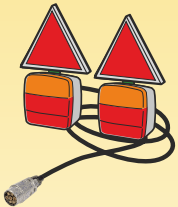

**KIT LUCI POSTERIORI
KIT DE LUCES TRASERAS**
Blitz 45-50 (KIT.LP.10.03)

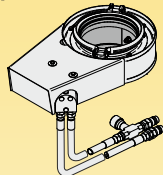

**GIREVOLE IDRAULICO
GIRATORIO HIDRÁULICO**
Blitz 45-50 (T.GIR.I.175T)

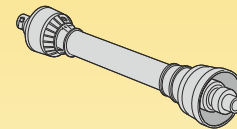

**CARDANO
CARDÁN**
Blitz 45 (KHP.050.110)
Blitz 50 (KHP.060.110)

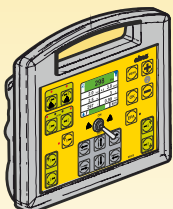

**SENSORI ULTRASUONI
SENSORES ULTRASONÍCOS**
Blitz 45-50 (D.SU2.EPA.T01)

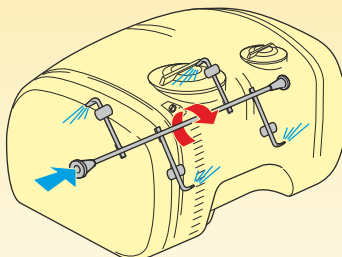

**IDROMISCELATORE ROTANTE A PALE
AGITADOR**
Blitz 50 lt.1000 - 1500

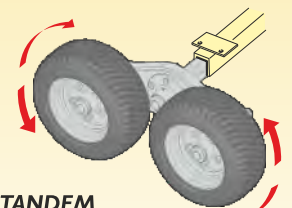

**ASSALI TANDEM
PAR DE RUEDAS TÁNDEM**
Blitz 45-50 lt.600-800-1000 ÉTROIT (DIFF.RT.T.07)
Blitz 50 lt.1000 (DIFF.RT.T.02)
Blitz 50 lt.1500 (DIFF.RT.T.06)



E.P.A.
Erogazione Proportionale Avanzamento
Débit Proportionnel à l'Avancement
Blitz 45-50 (EPA.T11)

**KIT EASY FARM
KIT EASY FARM**
Blitz 45-50 (K.EASYFARM.01)





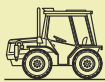

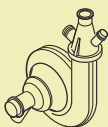
INFORMAZIONI TECNICHE

INFORMACIÓN TÉCNICA

		Blitz 45	Blitz 50
	TRATTRICE	potenza richiesta 33 kW - 45 CV	potenza richiesta 48 kW - 65 CV
	TRACTOR	potencia requerida 33 kW - 45 HP	potencia requerida 48 kW - 65 HP
	ATOMIZZATORE	potenza assorbita 17 kW - 23 CV	potenza assorbita 24 kW - 33 CV
	ATOMIZADOR	potencia absorbida 17 kW - 23 HP	potencia absorbida 24 kW - 33 HP
	VENTOLA	radiale in acciaio chiusa D.450 mm 4500 giri/min. - portata aria: 5400 m ³ /h - velocità aria: 188 m/s	radiale in acciaio chiusa D.500 mm 4000 giri/min. - portata aria: 7550 m ³ /h - velocità aria: 175 m/s
	VENTILADOR	radial de acero cerrada D. 450 mm 4500 rpm - caudal de aire: 5400 m ³ /h - velocidad del aire 188 m/s	radial de acero cerrada D. 500 mm 4000 rpm - caudal de aire: 7550 m ³ /h - velocidad del aire 175 m/s
	POMPA	centrifuga di alimentazione e agitazione CIMA CD 32 - 4250 giri/min. portata massima 140 l/min. - pressione massima 4,5 kg/cm ²	
	BOMBA	centrifuga de alimentación y agitación CIMA CD 32 - 4250 rpm caudal 140 l/min - presión máx. 4,5 kg/cm ²	

Valori suscettibili di variazioni in funzione del dispositivo di distribuzione utilizzato
Valores susceptibles de variación en función del dispositivo de distribución utilizado.

		Blitz 45				Blitz 50			
		I. 600	I. 800	I. 1000	I. 1000 stretto - estrecho	I. 800	I. 1000	I. 1000 stretto - estrecho	I. 1500
	LUNGHEZZA	299-343 cm	327-371 cm	321-361 cm	327-371 cm	337-381 cm	332-382 cm	337-381 cm	396-446 cm
	LONGITUD								
	LARGHEZZA	109-135 cm	109-135 cm	139-181 cm	113-139 cm	109-135 cm	139-181 cm	113-139 cm	167-209 cm
	ANCHO								
	ALTEZZA	133-145 cm	140-152 cm	141-153 cm	154-166 cm	140-152cm	141-153 cm	154-166 cm	150-162 cm
	ALTURA								
	PESO	375 kg	386 kg	434 kg	409 kg	456 kg	502 kg	481 kg	612 kg
	PESO ESTÁNDAR								
	RUOTE	7.00-12	7.00-12	10/80-12	10/80-12	7.00-12	10/80-12	10/80-12	10,0/75-15
	RUEDAS		10/80-12 (opt.)			10/80-12 (opt.)	10,0/75-15 (opt.)	10,0/75-15 (opt.)	

Le dimensioni e pesi sono a titolo indicativo e possono variare secondo la configurazione della macchina
Los pesos y dimensiones son indicativos y pueden variar según la configuración de la máquina

Nei paesi dell'Unione Europea le nostre attrezzature sono conformi alla Direttiva Europea "Macchine"; negli altri paesi sono conformi alle norme di sicurezza in vigore in quei paesi.



En los países de la Unión Europea, nuestros productos responden a la Directiva Europea "Máquinas"; en los demás países, responden a las normas de seguridad vigentes en los mismos.

cima[®]



RIVENDITORE AUTORIZZATO
REVENDEDOR AUTORIZADO

Loc. Molino Quaroni n.7, Montù Beccaria - PV - (ITALY)
Tel. +39.0385.246636 - www.cima.it

